

Service Kits .....	3-2, 3-3
Screen Cloth.....	3-4
Screen Spline .....	3-4
Screen Framing .....	3-5 to 3-6
Screen Corners .....	3-6 to 3-9
Screen Door Bug Bar .....	3-9 to 3-10
Screen Door Rollers .....	3-10 to 3-16
Screen Pulls .....	3-16 to 3-17
Screen Door Strikes .....	3-17
Screen Door Latches & Handles.....	3-17 to 3-20
Screen Clips .....	3-20 to 3-22
Screen Plunger Latches .....	3-22 to 3-23
Screen Latches & Tension Springs .....	3-23
Screen Guides .....	3-24
Jiffy Screen Hanger .....	3-24
Screen Track .....	3-24 to 3-25
Sliding SScreen Doors .....	3-25 to 3-26
Pet Screen Doors.....	3-26
Pet Doors .....	3-27
Screen Door Closer .....	3-27
Screen Wicket.....	3-27









SERVICE KITS

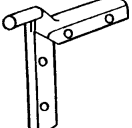
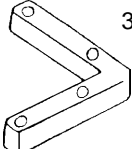
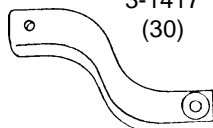
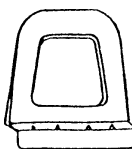
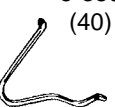
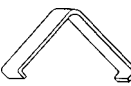

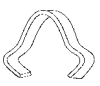
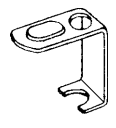
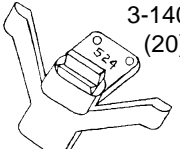
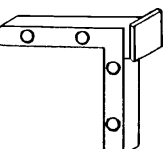
Window & Screen Hardware

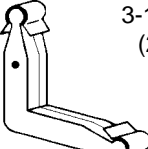
Part No. 3-WSK

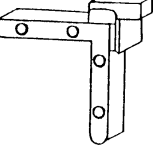
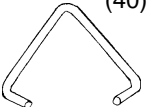
An assortment of these popular replacement parts is essential for window and screen repairs. Use on your sales counter, in your shop or take to the job. Parts are identified by number for easy reordering.

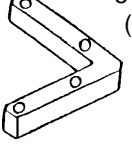
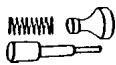
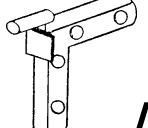
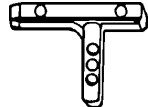
 5-374 (40)*	 3-1402 (40)		 3-1417 (30)		
 3-1400 (40)	 5-380 (40)	 5-382 (40)	 5-372 (40)	 5-370 (40)	 3-1409 A-E (40)
 3-1404 (20)	 5-379 (40)	 5-384 (40)	 3-1405L (20)	 3-1408 (20)	
 3-1410 A-H (40)	 5-378 (40)	 5-371 (40)	 3-1405R (20)	 5-377 (40)	
 3-1407 (40)	 5-375 (40)	 5-373 (20)			

\*Quantity in kit.

Take these kits to the job, use them in your shop or simply put one on your sales counter. All Glass Parts Inc. can **custom** make any number of kits to suit your specific requirements.

SERVICE KITS



Sliding Screen Door Rollers  
Part No. 3-SRK

Over 100 of the most popular screen rollers and corners are in this tough, durable suitcase-style kit. Use on your sales counter, in your shop or take to the job. Bulk-up on the popular rollers. Containers are numbered for easy identification and reordering.

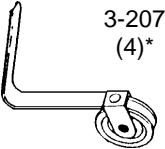
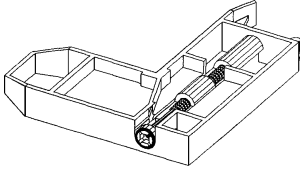
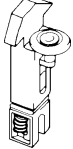
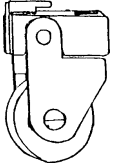
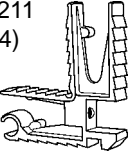
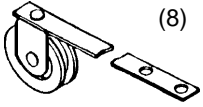
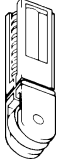
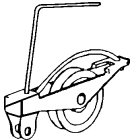
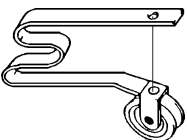
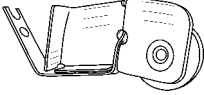
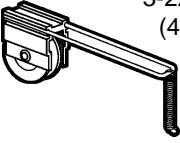
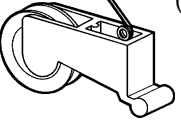
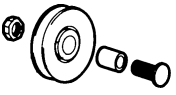
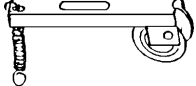
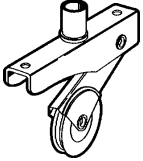
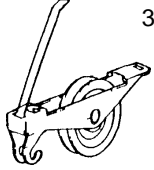
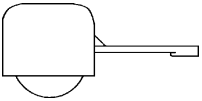
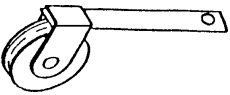
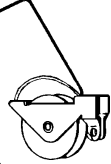
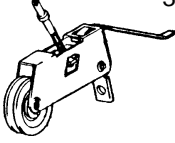
 <p>3-207 (4)*</p>	 <p>3-214 (4)</p>		 <p>3-226 (8)</p>	
 <p>3-206 (4)</p>	 <p>3-211 (4)</p>	 <p>3-217 (8)</p>	 <p>3-225 (8)</p>	
 <p>3-205 (8)</p>	 <p>3-210 (4)</p>	 <p>3-216 (4)</p>	 <p>3-223 (4)</p>	
 <p>3-202 (8)</p>	 <p>3-220 (4)</p>	 <p>3-208 (8)</p>	 <p>3-215 (4)</p>	 <p>3-209 (4)</p>
 <p>3-201 (8)</p>	 <p>3-224 (8)</p>		 <p>3-213 (4)</p>	 <p>3-219 (4)</p>

\*Quantity in kit.

Take these kits to the job, use them in your shop or simply put one on your sales counter. All Glass Parts Inc. can **custom** make any number of kits to suit your specific requirements.

## Screen Cloth

- Smaller 100' rolls enable you to stock more sizes and reduce waste.
- Save when you buy 600' and 800' fiberglass rolls —see price pages for details and pricing.

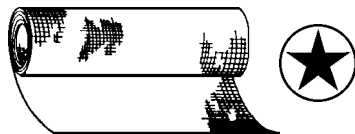

### Screen Cloth

Part Number	Width	Colour	Material
3-FGS-24	24"	Black	Fiberglass
3-FGS-30	30"	Black	Fiberglass
3-FGS-36	36"	Black	Fiberglass
3-FGS-42	42"	Black	Fiberglass
3-FGS-48	48"	Black	Fiberglass
3-FGS-60	60"	Black	Fiberglass
3-FGS-72	72"	Black	Fiberglass

3-BMS-24	24"	Black	Aluminum
3-BMS-30	30"	Black	Aluminum
3-BMS-36	36"	Black	Aluminum
3-BMS-42	42"	Black	Aluminum
3-BMS-48	48"	Black	Aluminum
3-BMS-60	60"	Black	Aluminum
3-BMS-72	72"	Black	Aluminum

3-CMS-24	24"	Clear	Aluminum
3-CMS-30	30"	Clear	Aluminum
3-CMS-36	36"	Clear	Aluminum
3-CMS-42	42"	Clear	Aluminum
3-CMS-48	48"	Clear	Aluminum
3-CMS-60	60"	Clear	Aluminum
3-CMS-72	72"	Clear	Aluminum

Roll Length: 100'

Mesh Count Per Inch: 18 x 16

Unit: Roll                      Bulk: 10 Rolls

Used By: Several Manufacturers

### Fabricated and K.D. Screen Door Kits

- Available in three finishes – brown, mill and white.
- Solid extruded frame sections.
- Fully adjustable steel ball bearing rollers.
- Easy to assemble and install.
- Can be fabricated to fit any size opening.

See pages 3-24 & 3-25 for details.

- The smallness of the hole is designed to provide protection from small flying insects known as Gnats or No-See-Ums.

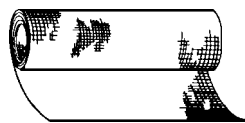

### No-See-Um Screen

Part Number	Width	Colour	Material
3-1476A	36"	Black	Fiberglass
3-1476B	48"	Black	Fiberglass

Roll Length: 100'

Mesh Count Per Inch: 20 x 20

Unit: Lineal Foot              Bulk: 100 Lin. Ft.

Used By: Several Manufacturers



### Heavy Duty Steel Screen Mesh

Part Number	Width	Colour	Material
3-1473	40"	Mill	Steel

Roll Length: 100'

Mesh Count Per Inch: 14 x 14

Wire Diameter: .023"

Opening Inch: .0484"

% of Open Area: 46.0

Unit: Lineal Foot              Bulk: N/A

Used By: Several Manufacturers

- Resists damage by cats and dogs.
- Made of strong vinyl-coated polyester.
- Excellent outward visibility.



### Pet-Resistant Insect Screen

Part Number	Width	Colour	Material
3-1475A	36"	Black	Polyester
3-1475B	48"	Black	Polyester

Roll Length: 100'

Unit: Lineal Foot              Bulk: 100 Lin. Ft.

Used By: Several Manufacturers

## Screen Spline

- Foam core type.
- Roll length may vary.
- We recommend stocking .160", .180" and .225" spline.



### Screen Spline — Foot

Part Number	Diameter	Bulk
3-SS-120	.120"	1000'
3-SS-140	.140"	900'
3-SS-160	.160"	600'
3-SS-180	.180"	500'
3-SS-200	.200"	400'
3-SS-225	.225"	300'
3-SS-250	.250"	200'

Type: Round Foam Type

Unit: Foot

Used By: Several Manufacturers

### Screen Spline — Roll

Part Number	Diameter	Roll Length
3-SS-120-R	.120"	5400'
3-SS-140-R	.140"	4500'
3-SS-160-R	.160"	2700'
3-SS-180-R	.180"	2250'
3-SS-200-R	.200"	1800'
3-SS-225-R	.225"	1500'
3-SS-250-R	.250"	1200'

Type: Round Foam Type

Unit: Roll                      Bulk: 5 Rolls

Used By: Several Manufacturers

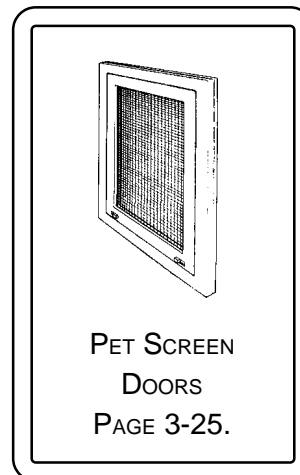

# SCREEN CLOTH, LINEALS & HARDWARE

- Uses corner 3-214, spline 3-SS-180 and wheels 3-205 or 3-213.

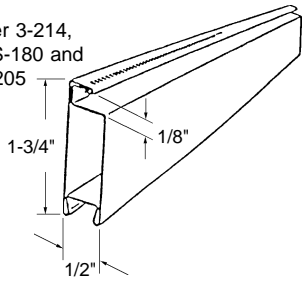

## Sliding Screen Door Bar

Part Number	Colour/Finish
<b>3-1431B</b>	<b>Brown</b>
<b>3-1431M</b>	<b>Mill</b>
<b>3-1431W</b>	<b>White</b>

Material: Roll Formed Aluminum  
 Stock Length: 161"  
 Unit: Foot      Bulk: 134 Ft.  
 Used By: Several Manufacturers

- Uses corner 3-287, spline 3-SS-200, wheels 3-240 or 3-242 and handle 3-251.

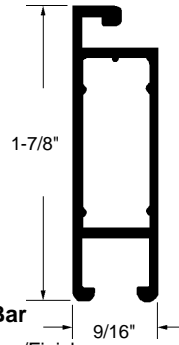

## Heavy Duty Sliding Screen Door Bar

Part Number	Colour/Finish
<b>3-1469B</b>	<b>Brown</b>
<b>3-1469M</b>	<b>Mill</b>
<b>3-1469W</b>	<b>White</b>

Material: Extruded Aluminum  
 Stock Length: 161"  
 Unit: Foot      Bulk: 134 Ft.  
 Manufactured By: All Glass Parts

- Uses corner 3-252, spline 3-SS-200, handle 3-250 and wheels 3-224 or 3-241S.

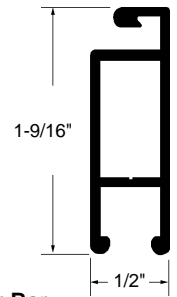

## Standard Sliding Screen Door Bar

Part Number	Colour/Finish
<b>3-1456B</b>	<b>Brown</b>
<b>3-1456M</b>	<b>Mill</b>
<b>3-1456W</b>	<b>White</b>

Material: Extruded Aluminum  
 Stock Length: 161"  
 Unit: Foot      Bulk: 134 Ft.  
 Used By: Several Manufacturers

- Uses corner 3-248, spline 3-SS-200, handle 3-247, locking handle 3-244 and wheel 3-215.

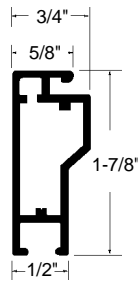

## Heavy Duty Extruded Sliding Screen Door Bar

Part Number	Colour/Finish
<b>3-1457B</b>	<b>Brown</b>
<b>3-1457M</b>	<b>Mill</b>
<b>3-1457W</b>	<b>White</b>

Material: Extruded Aluminum  
 Stock Length: 13'  
 Unit: Foot      Bulk: 134 Ft.  
 Used By: Several manufacturers

- Uses corner 3-1408, spline 3-SS-160 with metal screen or 3-SS-180 with fiberglass screen.

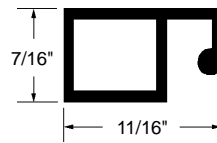

## Extruded Window Screen Bar

Part Number	Colour/Finish
<b>3-1433M</b>	<b>Mill</b>
<b>3-1433W</b>	<b>White</b>

Material: Extruded Aluminum  
 Stock Length: 18'  
 Unit: Foot      Bulk: 126 Ft.  
 Used By: Several Manufacturers

- Uses corner 3-1408, spline 3-SS-160 with metal screen or 3-SS-180 with fiberglass screen.

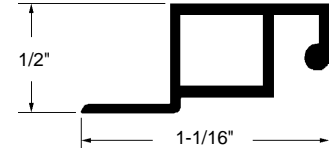

## Flanged Extruded Window Screen Bar

Part Number	Colour/Finish
<b>3-1434M</b>	<b>Mill</b>
<b>3-1434W</b>	<b>White</b>

Material: Extruded Aluminum  
 Stock Length: 18'  
 Unit: Foot      Bulk: 126 Ft.  
 Used By: Several Manufacturers

- Uses corner 5-377 and spline 3-SS-225.

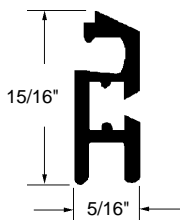

## Extruded Window Screen Bar

Part Number	Colour
<b>3-1435-C</b>	<b>White</b>

Material: Extruded Aluminum  
 Stock Length: 18'  
 Unit: Foot      Bulk: 126 Ft.  
 Used By: Wescab

- Uses corner 3-1402, spline 3-SS-180 with metal screen or 3-SS-200 with fiberglass screen.

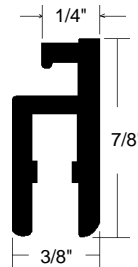

## Extruded Window Screen Bar

Part Number	Colour
<b>3-1470B</b>	<b>Brown</b>

Material: Extruded Aluminum  
 Stock Length: 14'  
 Unit: Foot      Bulk: 126 Ft.  
 Used By: Indal

- Uses corner 3-1402, spline 3-SS-180 with metal screen or 3-SS-200 with fiberglass screen.

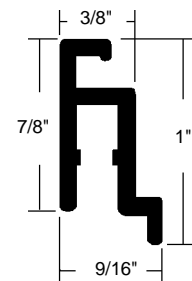

## Flanged Extruded Window Screen Bar

Part Number	Colour
<b>3-1471B</b>	<b>Brown</b>

Material: Extruded Aluminum  
 Stock Length: 14'  
 Unit: Foot      Bulk: 126 Ft.  
 Used By: Indal

# SCREEN CLOTH, LINEALS & HARDWARE

•Uses metal corners 3-SC-7/16 for mitered applications or 3-SCB(S)(W)-7/16 for non-mitered applications.

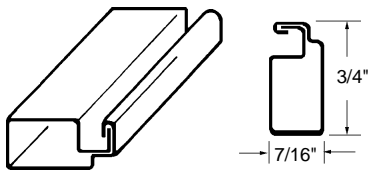

## Window Screen Framing

Part Number Colour/Finish

**3-SB-7/16-B** **Brown**

**3-SB-7/16-M** **Mill**

**3-SB-7/16-W** **White**



Material: Aluminum

Stock Length: 12' 2"

Metal Thickness: .022"

Unit: S/L

Bulk: 70 S/L

Used By: Several Manufacturers

•Uses metal corners 3-SC-3/8 for mitered applications or 3-SCB(S)(W)-3/8 for non-mitered applications.

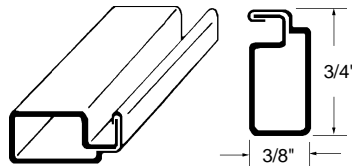

## Window Screen Framing

Part Number Colour/Finish

**3-SB-3/8-B** **Brown**

**3-SB-3/8-M** **Mill**

**3-SB-3/8-W** **White**



Material: Aluminum

Stock Length: 12' 2"

Metal Thickness: .022"

Unit: S/L

Bulk: 81 S/L

Used By: Several Manufacturers

•Uses metal corners 3-SC-3/8-F for mitered applications or 3-SCB(S)(W)-3/8-F for non-mitered applications.

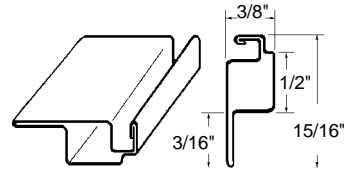

## Flanged Window Screen Framing

Part Number Colour/Finish

**3-SBF-3/8-B** **Brown**

**3-SBF-3/8-M** **Mill**

**3-SBF-3/8-W** **White**

Material: Aluminum

Stock Length: 12' 2"

Metal Thickness: .018"

Unit: S/L

Bulk: 80 S/L

Used By: Several Manufacturers

•Uses metal corners 3-SC-3/8-F for mitered applications or 3-SCB(S)(W)-3/8-FO for non-mitered applications.

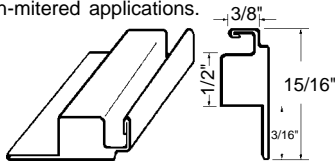

## Reverse Flanged Window Screen Framing

Part Number Colour/Finish

**3-SBFO-3/8-B** **Brown**

**3-SBFO-3/8-M** **Mill**

**3-SBFO-3/8-W** **White**

Material: Aluminum

Stock Length: 12' 2"

Metal Thickness: .018"

Unit: S/L

Bulk: 80 S/L

Used By: Several Manufacturers

•Uses metal corners 3-SC-5/16 for mitered applications or 3-SCB(S)(W)-5/16 for non-mitered applications.

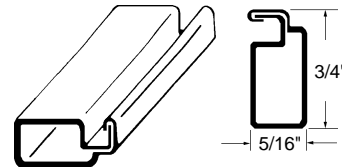

## Window Screen Framing

Part Number Colour/Finish

**3-SB-5/16-B** **Brown**

**3-SB-5/16-M** **Mill**

**3-SB-5/16-W** **White**

Material: Aluminum

Stock Length: 12' 7"

Metal Thickness: .022"

Unit: S/L

Bulk: 75 S/L

Used By: Several Manufacturers

•Uses metal corners 3-SC-1/4 for mitered applications or 3-SCB(S)(W)-1/4 for non-mitered applications.

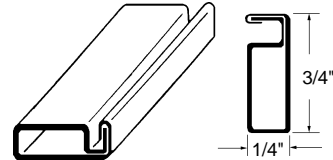

## Window Screen Framing

Part Number Colour/Finish

**3-SB-1/4-B** **Brown**

**3-SB-1/4-M** **Mill**

**3-SB-1/4-W** **White**

Material: Aluminum

Stock Length: 12' 6"

Metal Thickness: .018"

Unit: S/L

Bulk: 100 S/L

Used By: Several Manufacturers

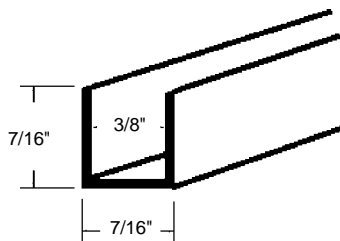

## Window Screen Track

Part Number Colour

**3-1466** **White**

Material: Plastic

Stock Length: 12'

Unit: S/L

Bulk: 20 S/L

Used By: Several Manufacturers

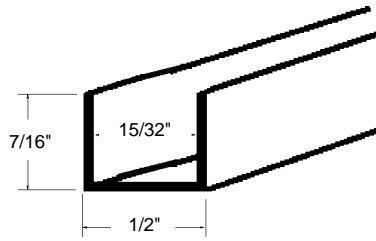

## Window Screen Track

Part Number Colour

**3-1468** **White**

Material: Plastic

Stock Length: 12'

Unit: S/L

Bulk: 20 S/L

Used By: Several Manufacturers

•For mitered application.

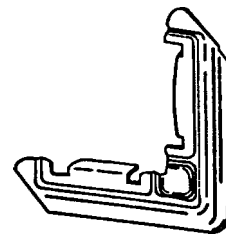

## Window Screen Corner

Part Number Bar Size Bar Type

**3-SC-7/16** **7/16"** **Regular**

**3-SC-3/8** **3/8"** **Regular**

**3-SC-3/8-F** **3/8"** **Flanged**

**3-SC-5/16** **5/16"** **Regular**

**3-SC-1/4** **1/4"** **Regular**

Material: Aluminum

Unit: Each

Bulk: 400 Pcs.

Used By: Several Manufacturers

# SCREEN CLOTH, LINEALS & HARDWARE

•Sold in sets of 4 only.

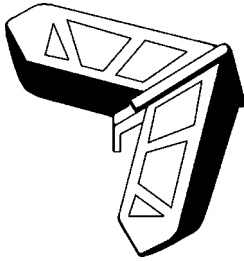

### Window Screen Corner

Part Number	Colour
<b>3-1467-B</b>	<b>Brown</b>
<b>3-1467-C</b>	<b>Champagne</b>
<b>3-1467-W</b>	<b>White</b>

Material: Plastic  
Unit: Set of 4      Bulk: 10 Sets  
Used By: Pella

- For non-mitered application.
- Used on 7/16" Indal screen bar.
- Does not fit on AGP screen bar.

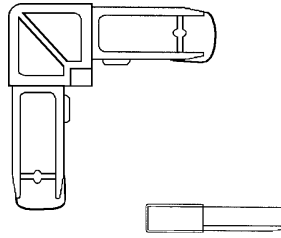

### Window Screen Corner

Part Number	Colour
<b>3-1439</b>	<b>Light Brown</b>

Material: Plastic  
Bar Size: 7/16"  
Unit: Each      Bulk: 25 Pcs.  
Used By: Indal

**Discontinued** •Replacement: 5-377 (page 5-13).

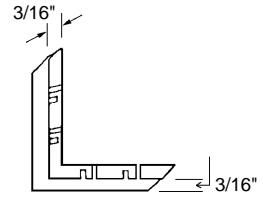

### Screen or Sash Corner

Part Number
<b>3-1401</b>

Material: Aluminum  
Finish: Mill  
Unit: N/A  
Used By: Wescab

- For non-mitered application.
- Just press into place for perfect fit.
- Corners have channel for screen spline.
- Close colour match to screen bar.

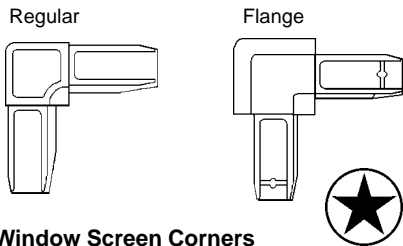

### Window Screen Corners

Part Number	Colour	Bar Type
<b>3-SCB-7/16</b>	<b>Brown</b>	<b>Regular</b>
<b>3-SCS-7/16</b>	<b>Silver</b>	<b>Regular</b>
<b>3-SCW-7/16</b>	<b>White</b>	<b>Regular</b>
<b>3-SCB-3/8</b>	<b>Brown</b>	<b>Regular</b>
<b>3-SCS-3/8</b>	<b>Silver</b>	<b>Regular</b>
<b>3-SCW-3/8</b>	<b>White</b>	<b>Regular</b>
<b>3-SCB-3/8-F</b>	<b>Brown</b>	<b>Flange</b>
<b>3-SCS-3/8-F</b>	<b>Silver</b>	<b>Flange</b>
<b>3-SCW-3/8-F</b>	<b>White</b>	<b>Flange</b>
<b>3-SCB-3/8-FO</b>	<b>Brown</b>	<b>Rev. Flange</b>
<b>3-SCS-3/8-FO</b>	<b>Silver</b>	<b>Rev. Flange</b>
<b>3-SCW-3/8-FO</b>	<b>White</b>	<b>Rev. Flange</b>
<b>3-SCB-5/16</b>	<b>Brown</b>	<b>Regular</b>
<b>3-SCS-5/16</b>	<b>Silver</b>	<b>Regular</b>
<b>3-SCW-5/16</b>	<b>White</b>	<b>Regular</b>
<b>3-SCB-1/4</b>	<b>Brown</b>	<b>Regular</b>
<b>3-SCS-1/4</b>	<b>Silver</b>	<b>Regular</b>
<b>3-SCW-1/4</b>	<b>White</b>	<b>Regular</b>

Material: Plastic  
Unit: Each      Bulk: 400 Pcs.  
Used By: Several Manufacturers

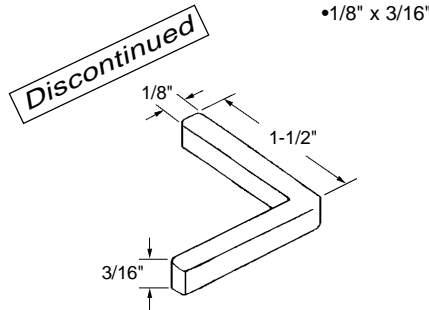

### Screen or Sash Corner

Part Number
<b>3-1464</b>

Material: Aluminum  
Finish: Mill  
Unit: N/A  
Used By: Several Manufacturers

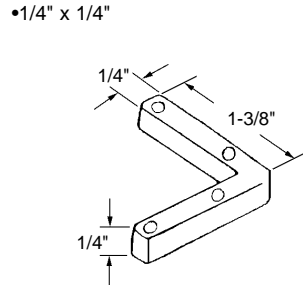

### Screen or Sash Corner

Part Number
<b>3-1402</b>

Material: Die Cast  
Finish: Mill  
Unit: Each      Bulk: 100 Pcs.  
Used By: Several Manufacturers

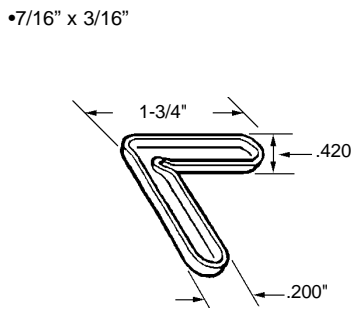

### Screen or Sash Corner

Part Number
<b>3-1420</b>

Material: Aluminum  
Finish: Mill  
Unit: Each      Bulk: 50 Pcs.  
Used By: Several Manufacturers

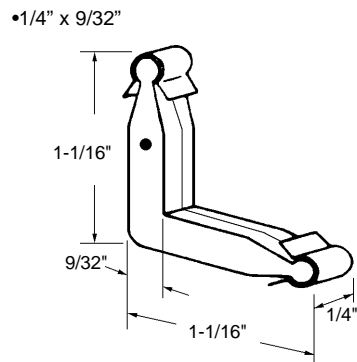

### Screen or Sash Corner

Part Number
<b>3-1408</b>

Material: Die Cast  
Finish: Mill  
Unit: Each      Bulk: 100 Pcs.  
Used By: Several Manufacturers

•1/8" x 5/16"

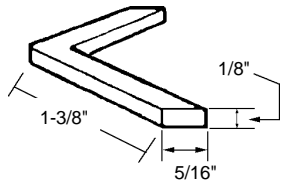

**Screen or Sash Corner**

Part Number  
**3-1421**  
 Material: Aluminum  
 Finish: Mill  
 Unit: Each      Bulk: 50 Pcs.  
 Used By: Several Manufacturers

**Discontinued**

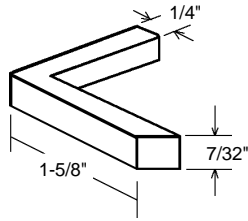

**Screen or Sash Corner**

Part Number  
**3-1403**  
 Material: Aluminum  
 Finish: Mill  
 Unit: N/A  
 Used By: Several Manufacturers

•Holes: 2 @ .106" Dia.  
 \*21/32"  $\phi$  holes to end of corner.

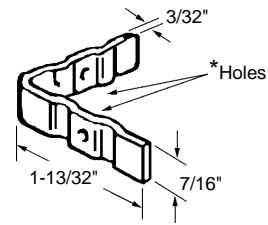

**Screen or Sash Corner**

Part Number  
**3-1437**  
 Material: Aluminum  
 Unit: Each      Bulk: 50 Pcs.  
 Used By: Indal

•Use with 3-202 sliding screen door roller.

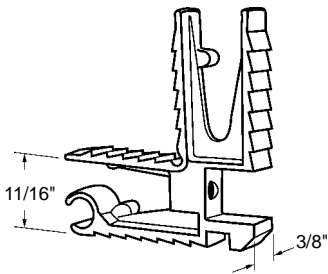

**Sliding Screen Door Corner**

Part Number  
**3-211**  
 Material: Die Cast  
 Finish: Mill  
 Unit: Each      Bulk: 20 Pcs.  
 Used By: Indal

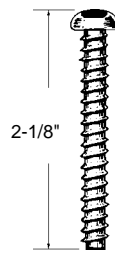

**Special Tapered Screw for 3-211 Corner**

Part Number  
**3-211S**  
 Material: Metal  
 Finish: Mill  
 Unit: Each      Bulk: 20 Pcs.  
 Used By: Indal

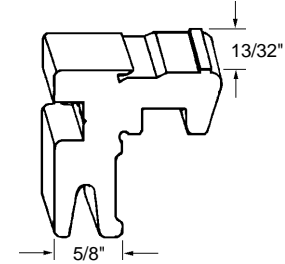

**Sliding Screen Door Corner**

Part Number  
**3-273**  
 Material: Aluminum  
 Finish: Mill  
 Unit: Each      Bulk: 20 Pcs.  
 Used By: Zimmcor

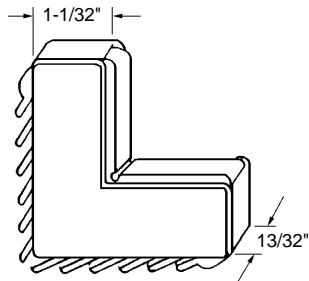

**Sliding Screen Door Corner**

Part Number  
**3-272**  
 Material: Plastic  
 Colour: Black  
 Unit: Each      Bulk: 20 Pcs.  
 Used By: Almetco

•Used on 3-1457 screen bar, page 3-4.

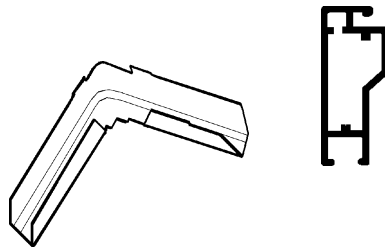

**Sliding Screen Door Corner**

Part Number  
**3-248**  
 Material: Galvanized Steel  
 Finish: Mill  
 Unit: Each      Bulk: 20 Pcs.  
 Used By: Several Manufacturers

**Discontinued**

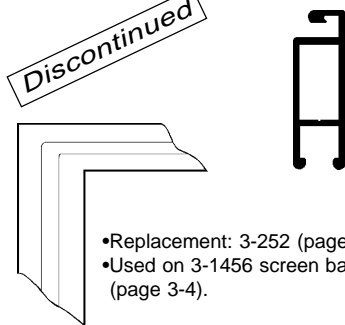

•Replacement: 3-252 (page 3-8).  
 •Used on 3-1456 screen bar (page 3-4).

**Sliding Screen Door Corner**

Part Number  
**3-249**  
 Material: Galvanized Steel  
 Finish: Mill  
 Unit: N/A  
 Used By: Several Manufacturers



# SCREEN CLOTH, LINEALS & HARDWARE

•Used on 3-1456 screen bar, page 3-4.

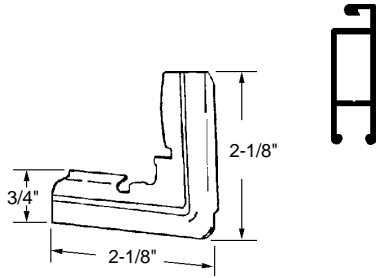

### Sliding Screen Door Corner

Part Number

**3-252**

Material: Galvanized Steel

Finish: Mill

Unit: Each

Bulk: 20 Pcs.

Used By: Several Manufacturers

•Used with 3-213 type rollers, page 3-14.

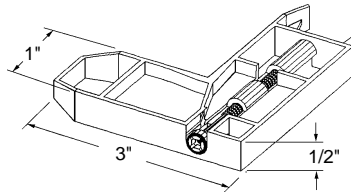

### Sliding Screen Door Corner

Part Number

**3-204**

Material: Die Cast

Finish: Mill

Unit: Each

Bulk: 100 Pcs.

Used By: Several Manufacturers

•Used with 3-213 type rollers, page 3-14.

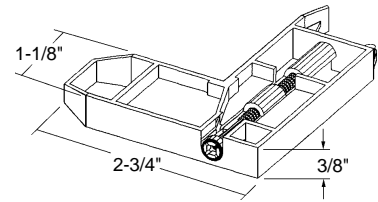

### Sliding Screen Door Corner

Part Number

**3-214**

Material: Die Cast

Finish: Mill

Unit: Each

Bulk: 100 Pcs.

Used By: Several Manufacturers



•Narrow style corner.  
•Used with 3-240 or 3-242 roller.

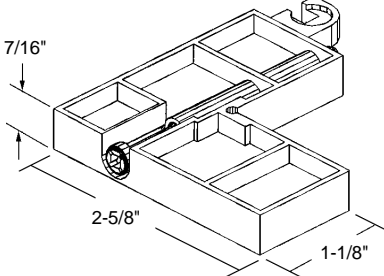

### Sliding Screen Door Corner

Part Number

**3-287**

Material: Die Cast

Finish: Mill

Unit: Each

Bulk: 100 Pcs.

Used By: Several Manufacturers



•Wide style corner.  
•Used with 3-240 or 3-242 roller.

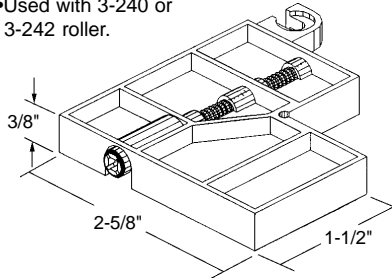

### Sliding Screen Door Corner

Part Number

**3-288**

Material: Die Cast

Finish: Mill

Unit: Each

Bulk: 100 Pcs.

Used By: Several Manufacturers

FOR MORE  
SCREEN/SASH  
CORNERS  
SEE SECTION 5  
AND  
SECTION 8.

•Fits screen bars 3-1469B(M)(W),  
3-1431B(M)(W), 3-1456B(M)(W) and  
3-1457B(M)(W).

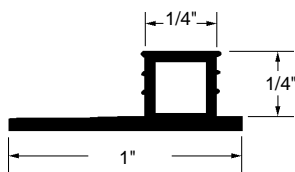

### Sliding Screen Door Bug Bar

Part Number

**3-1458**

Material: PVC Flex

Colour: White

Length: 83"

Unit: Each

Bulk: 25 Pcs.

Used By: Several Manufacturers

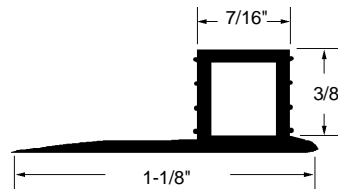

### Sliding Screen Door Bug Bar

Part Number

**3-1453**

Material: PVC Flex

Colour: Black

Unit: Foot

Bulk: 200 Ft.

Used By: Several Manufacturers

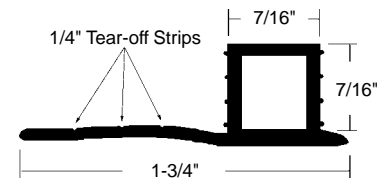

### Sliding Screen Door Bug Bar

Part Number

**3-1472**

Material: PVC Flex

Colour: Black

Unit: Foot

Bulk: 200 Ft.

Used By: Several Manufacturers

# SCREEN CLOTH, LINEALS & HARDWARE

•Fits screen bars 3-1469B(M)(W), 3-1431B(M)(W), 3-1456B(M)(W) and 3-1457B(M)(W).

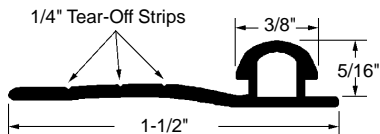

## Sliding Screen Door Bug Bar

Part Number

**3-1459**

Material: PVC Flex

Colour: Black

Unit: Foot

Bulk: 200 Ft.

Used By: Several Manufacturers

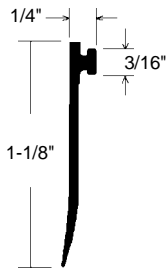

## Sliding Screen Door Bug Bar

Part Number

**3-1452**

Material: PVC Flex

Colour: Grey

Unit: Foot

Bulk: 200 Ft.

Used By: Several Manufacturers

•Use with 3-211 sliding screen door corner.

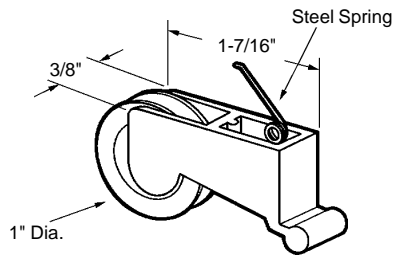

## Sliding Screen Door Roller

Part Number

**3-202**

Housing: Plastic

Wheel: Plastic

Unit: Each

Bulk: 100 Pcs.

Used By: Indal

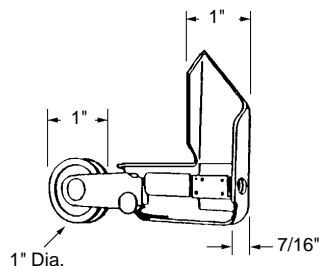

## Sliding Screen Door Roller

Part Number

**3-203**

Housing: Metal

Wheel: Plastic

Unit: Each

Bulk: 10 Pcs.

Used By: Walters

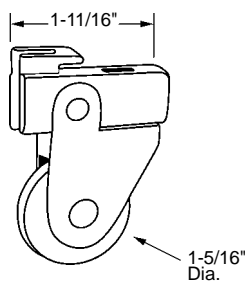

## Sliding Screen Door Roller

Part Number

**3-206**

Housing: Plastic

Wheel: Plastic

Unit: Each

Bulk: 10 Pcs.

Used By: Solaris

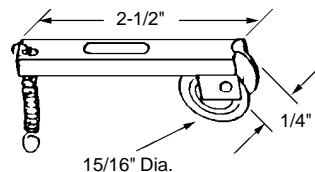

## Sliding Screen Door Roller

Part Number

**3-208**

Housing: Aluminum

Wheel: Plastic

Unit: Each

Bulk: 20 Pcs.

Used By: Prime-Tech

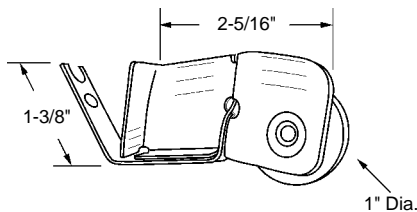

## Sliding Screen Door Roller

Part Number

**3-216**

Housing: Metal

Wheel: Nylon Wheel

Unit: Each

Bulk: 10 Pcs.

Used By: International

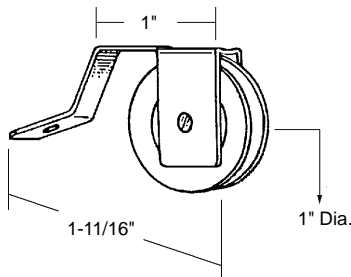

## Sliding Screen Door Roller

Part Number

**3-241**

Housing: Metal

Wheel: Nylon Wheel

Unit: Each

Bulk: 20 Pcs.

Used By: Metal Industries

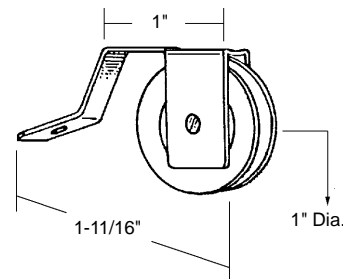

## Sliding Screen Door Roller

Part Number

**3-241S**

Housing: Metal

Wheel: Steel Ball Bearing

Unit: Each

Bulk: 20 Pcs.

Used By: Metal Industries

# SCREEN CLOTH, LINEALS & HARDWARE

- Bottom Roller.
- Used with roller 3-226.

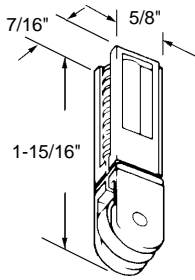

## Sliding Screen Door Roller

Part Number  
**3-225**  
 Housing: Plastic  
 Wheel: Plastic Wheel  
 Unit: Each      Bulk: 10 Pcs.  
 Used By: HiLite

- Top Roller.
- Used with roller 3-225.

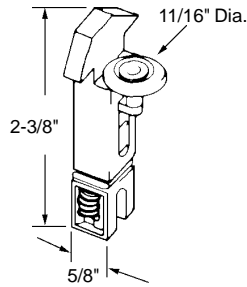

## Sliding Screen Door Roller

Part Number  
**3-226**  
 Housing: Plastic  
 Wheel: Plastic Wheel  
 Unit: Each      Bulk: 10 Pcs.  
 Used By: HiLite

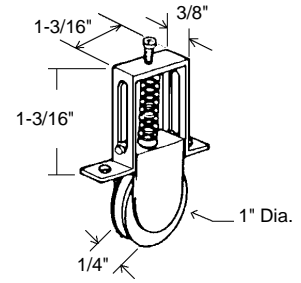

## Sliding Screen Door Roller

Part Number  
**3-239**  
 Housing: Nylon  
 Wheel: Steel Ball Bearing  
 Unit: Each      Bulk: 10 Pcs.  
 Used By: Columbia

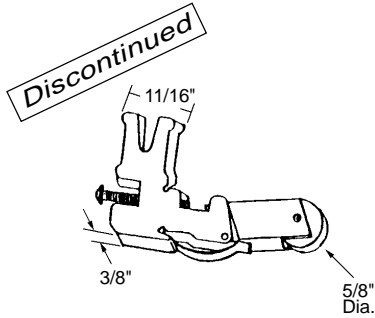

## Sliding Screen Door Roller

Part Number  
**3-212**  
 Housing: Aluminum  
 Wheel: Nylon  
 Unit: N/A  
 Used By: Zimcor

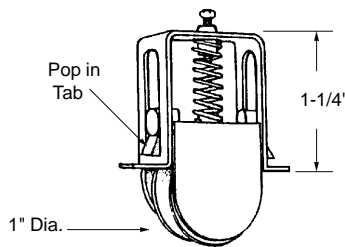

## Sliding Screen Door Roller

Part Number  
**3-297**  
 Housing: Plastic  
 Wheel: Plastic  
 Unit: Each      Bulk: 20 Pcs.  
 Used By: Columbia

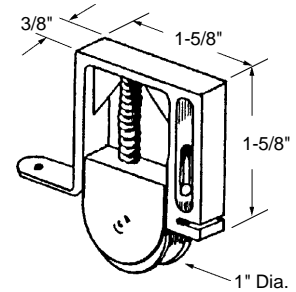

## Sliding Screen Door Roller

Part Number  
**3-296**  
 Housing: Plastic  
 Wheel: Steel  
 Unit: Each      Bulk: 20 Pcs.  
 Used By: Academy

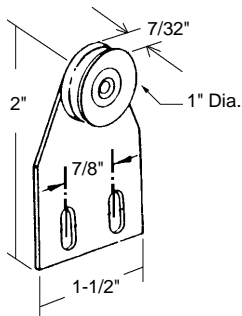

## Sliding Screen Door Roller

Part Number  
**3-235**  
 Housing: Metal  
 Wheel: Steel Ball Bearing  
 Unit: Each      Bulk: 10 Pcs.  
 Used By: Fullview

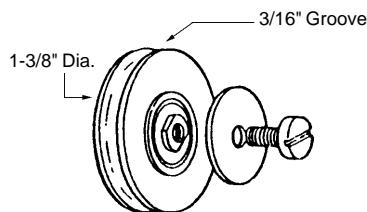

## Sliding Screen Door Roller

Part Number  
**3-232**  
 Housing: Metal  
 Wheel: Plastic  
 Unit: Each      Bulk: 10 Pcs.  
 Used By: Arcadia

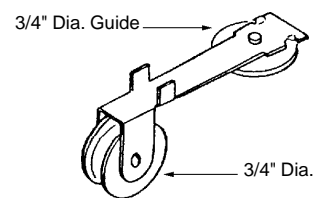

## Sliding Screen Door Roller

Part Number  
**3-294**  
 Housing: Metal  
 Wheel: Plastic  
 Unit: Each      Bulk: 10 Pcs.  
 Used By: Arcadia

- Bottom Roller.
- 3-230 Stud not included.
- Used with roller 3-229.

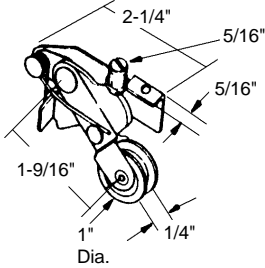

**Sliding Screen Door Roller**

Part Number

**3-228**

Housing: Metal

Wheel: Plastic Wheel

Unit: Each

Bulk: 20 Pcs.

Used By: R.O.W.



- Top Roller.
- Used with roller 3-228.

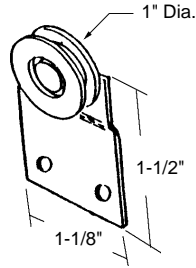

**Sliding Screen Door Roller**

Part Number

**3-229**

Housing: Metal

Wheel: Plastic Wheel

Unit: Each

Bulk: 20 Pcs.

Used By: R.O.W.

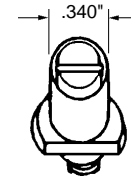

**Sliding Screen Door Adjustment Stud for 3-228 Roller**

Part Number

**3-230**

Material: Metal

Unit: Each

Bulk: 20 Pcs.

Used By: R.O.W.

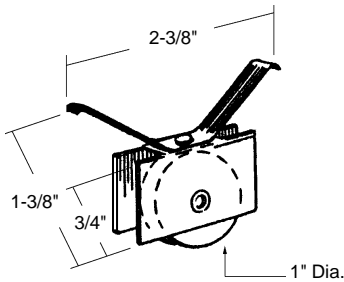

**Sliding Screen Door Roller**

Part Number

**3-298**

Housing: Metal

Wheel: Plastic

Unit: Each

Bulk: 20 Pcs.

Used By: Keller

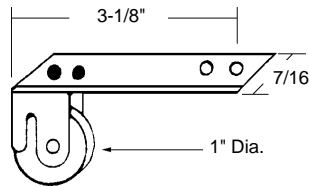

**Sliding Screen Door Roller**

Part Number

**3-236**

Housing: Metal

Wheel: Plastic

Unit: Each

Bulk: 5 Pcs.

Used By: Andersen

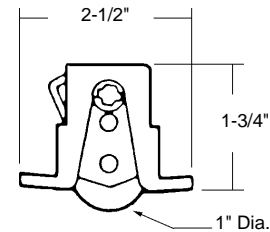

**Sliding Screen Door Roller**

Part Number

**3-237**

Housing: Aluminum/Plastic

Wheel: Plastic

Unit: Each

Bulk: 5 Pcs.

Used By: Andersen

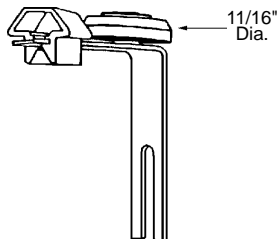

**Sliding Screen Door Roller & Top Guide**

Part Number

**3-295**

Housing: Metal

Wheel: Nylon

Unit: Each

Bulk: 20 Pcs.

Used By: Ador/HiLite

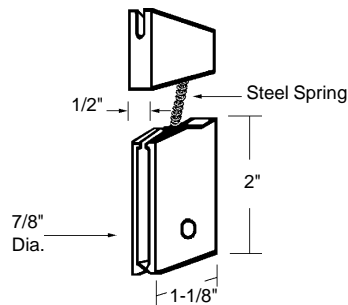

**Sliding Screen Door Roller**

Part Number

**3-277**

Housing: Plastic

Wheel: Plastic

Unit: Each

Bulk: 10 Pcs.

Used By: P.H. Tech

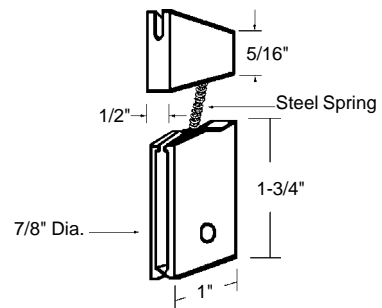

**Sliding Screen Door Roller**

Part Number

**3-279**

Housing: Plastic

Wheel: Plastic

Unit: Each

Bulk: 10 Pcs.

Used By: P.H. Tech

# SCREEN CLOTH, LINEALS & HARDWARE

•3/8" x 3/4" Housing

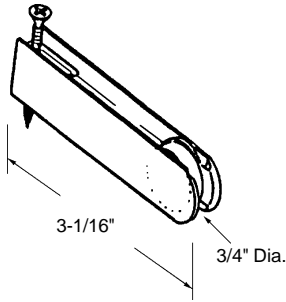

### Sliding Screen Door Roller

Part Number

**3-269**

Housing: Nylon

Wheel: Nylon

Unit: Each Bulk: 20 Pcs.

Used By: Weathershield

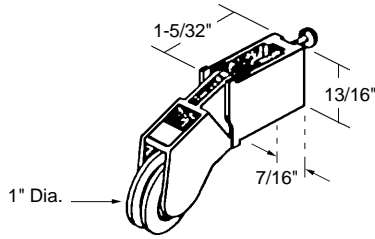

### Sliding Screen Door Roller

Part Number

**3-243**

Housing: Nylon

Wheel: Nylon

Unit: Each Bulk: 10 Pcs.

Used By: Peachtree

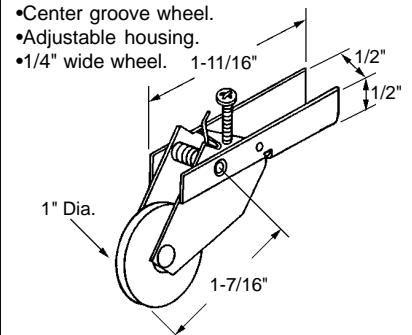

### Sliding Screen Door Roller

Part Number

**3-307**

Housing: Steel

Wheel: Nylon Ball Bearing

Unit: Each Bulk: 10 Pcs.

Used By: Peachtree

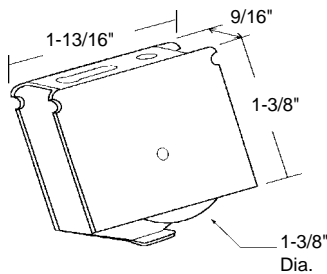

### Sliding Screen Door Roller

Part Number

**3-305**

Housing: Aluminum

Wheel: Plastic

Unit: Each Bulk: 10 Pcs.

Used By: Pella

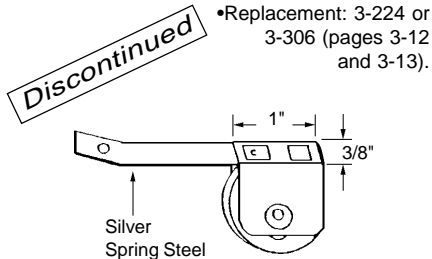

### Sliding Screen Door Roller

Part Number

**3-200**

Wheel Material: Nylon

Colour: White

Wheel Dia.: 1"

Unit: N/A

Used By: Several Manufacturers

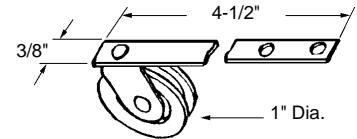

### Sliding Screen Door Roller

Part Number

**3-222**

Housing: Metal

Wheel: Steel Ball Bearing

Unit: Each Bulk: 10 Pcs.

Used By: Several Manufacturers

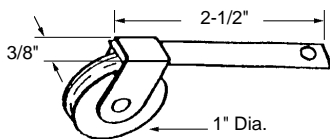

### Sliding Screen Door Roller

Part Number

**3-224**

Housing: Metal

Wheel: Steel Ball Bearing

Unit: Each Bulk: 50 Pcs.

Used By: Several Manufacturers

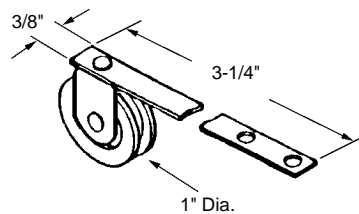

### Sliding Screen Door Roller

Part Number

**3-217**

Housing: Metal

Wheel: Steel Ball Bearing

Unit: Each Bulk: 20 Pcs.

Used By: Several Manufacturers

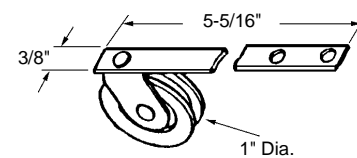

### Sliding Screen Door Roller

Part Number

**3-221**

Housing: Metal

Wheel: Steel Ball Bearing

Unit: Each Bulk: 10 Pcs.

Used By: Several Manufacturers

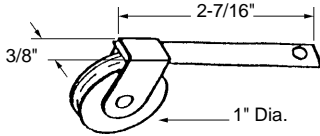

**Sliding Screen Door Roller**

Part Number  
**3-306**  
 Housing: Metal  
 Wheel: Plastic Wheel  
 Unit: Each      Bulk: 50 Pcs.  
 Used By: Several Manufacturers

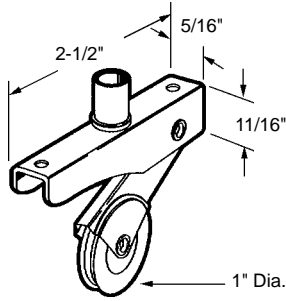

**Sliding Screen Door Roller**

Part Number  
**3-215**  
 Housing: Metal  
 Wheel: Steel Ball Bearing  
 Unit: Each      Bulk: 20 Pcs.  
 Used By: Several Manufacturers

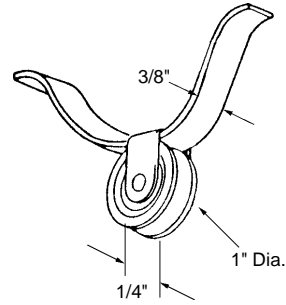

**Sliding Screen Door Roller**

Part Number  
**3-238**  
 Housing: Metal  
 Wheel: Steel Ball Bearing  
 Unit: Each      Bulk: 10 Pcs.  
 Used By: Several Manufacturers

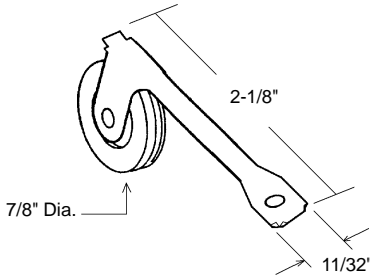

**Sliding Screen Door Roller**

Part Number  
**3-278**  
 Housing: Metal  
 Wheel: Nylon Ball Bearing  
 Unit: Each      Bulk: 10 Pcs.  
 Used By: Several Manufacturers

- Used with 3-287 or 3-288 corner (page 3-8).
- Nylon wheel.

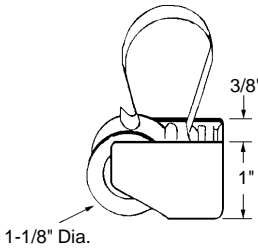

**Sliding Screen Door Roller**

Part Number  
**3-240**  
 Housing: Die Cast  
 Wheel: Nylon  
 Unit: Each      Bulk: 50 Pcs.  
 Used By: Several Manufacturers

- Used with 3-287 or 3-288 corner (page 3-8).
- Steel wheel.

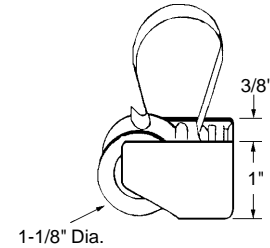

**Sliding Screen Door Roller**

Part Number  
**3-242**  
 Housing: Die Cast  
 Wheel: Steel Ball Bearing  
 Unit: Each      Bulk: 50 Pcs.  
 Used By: Several Manufacturers

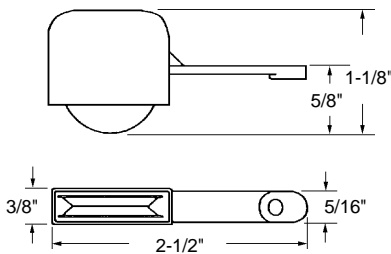

**Sliding Screen Door Roller**

Part Number  
**3-201**  
 Housing: Nylon  
 Wheel: Nylon  
 Unit: Each      Bulk: 20 Pcs.  
 Used By: Several Manufacturers

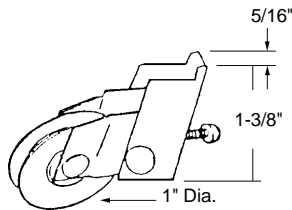

**Sliding Screen Door Roller**

Part Number  
**3-233**  
 Housing: Steel  
 Wheel: Steel  
 Unit: Each      Bulk: 20 Pcs.  
 Used By: Several Manufacturers

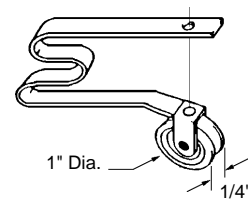

**Sliding Screen Door Roller**

Part Number	Wheel
<b>3-210</b>	<b>Nylon</b>
<b>3-210S</b>	<b>Steel Ball Bearing</b>
Housing: Metal	
Wheel: Nylon Wheel	
Unit: Each      Bulk: 30 Pcs.	
Used By: Several Manufacturers	

# SCREEN CLOTH, LINEALS & HARDWARE

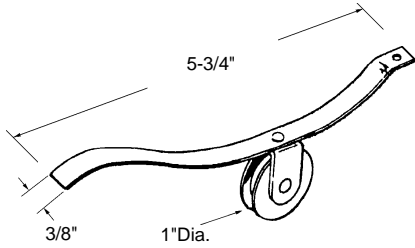

### Sliding Screen Door Roller

Part Number  
**3-291**  
 Housing: Steel  
 Wheel: Steel Ball Bearing  
 Unit: Each      Bulk: 10 Pcs.  
 Used By: Several Manufacturers

- High tension steel spring.
- Wheel with centre groove.

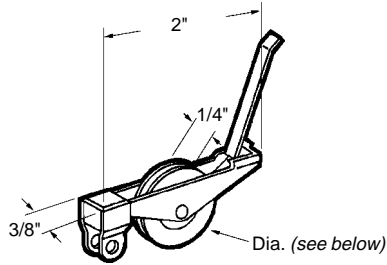

### Sliding Screen Door Roller

Part Number	Wheel Dia.
<b>3-308</b>	1"
<b>3-308-A</b>	1-1/4"

Housing: Steel  
 Wheel: Nylon  
 Unit: Each      Bulk: 50 Pcs.  
 Used By: Several Manufacturers

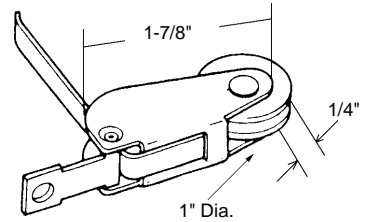

### Sliding Screen Door Roller

Part Number  
**3-234**  
 Housing: Steel  
 Wheel: Plastic  
 Unit: Each      Bulk: 20 Pcs.  
 Used By: Several Manufacturers

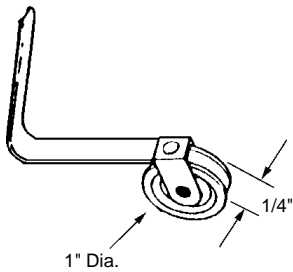

### Sliding Screen Door Roller

Part Number  
**3-207**  
 Housing: Metal  
 Wheel: Steel Ball Bearing  
 Unit: Each      Bulk: 20 Pcs.  
 Used By: Several Manufacturers

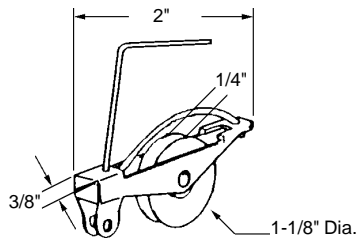

### Sliding Screen Door Roller

Part Number  
**3-205**   
 Housing: Metal  
 Wheel: Steel Ball Bearing  
 Unit: Each      Bulk: 50 Pcs.  
 Used By: Several Manufacturers

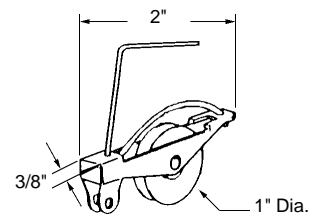

### Sliding Screen Door Roller

Part Number	Wheel
<b>3-303</b>	Steel Ball Bearing
<b>3-303-N</b>	Nylon

Housing: Metal  
 Unit: Each      Bulk: 50 Pcs.  
 Used By: Several Manufacturers

- Housing Width: 3/8".

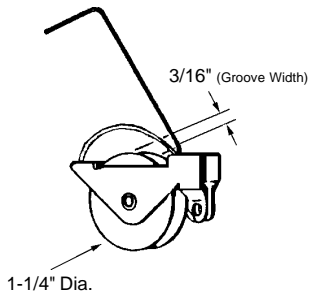

### Sliding Screen Door Roller

Part Number  
**3-213**   
 Housing: Metal  
 Wheel: Nylon Wheel  
 Unit: Each      Bulk: 100 Pcs.  
 Used By: Several Manufacturers

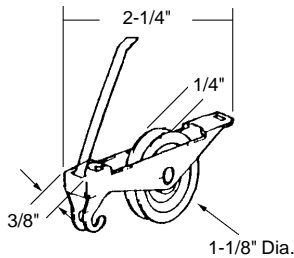

### Sliding Screen Door Roller

Part Number  
**3-209**   
 Housing: Metal  
 Wheel: Nylon  
 Unit: Each      Bulk: 20 Pcs.  
 Used By: Several Manufacturers

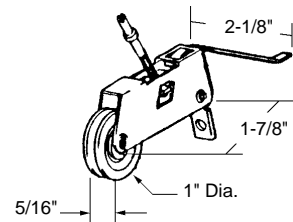

### Sliding Screen Door Roller

Part Number  
**3-219**  
 Housing: Metal  
 Wheel: Nylon Wheel  
 Unit: Each      Bulk: 10 Pcs.  
 Used By: Several Manufacturers

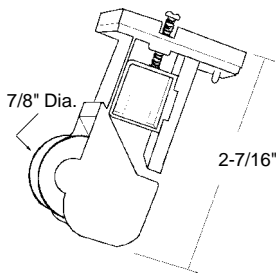

**Sliding Screen Door Roller**

Part Number      Colour  
**3-271**              **Black**  
 Housing: Plastic  
 Wheel: Plastic  
 Unit: Each          Bulk: 10 Pcs.  
 Used By: Several Manufacturers

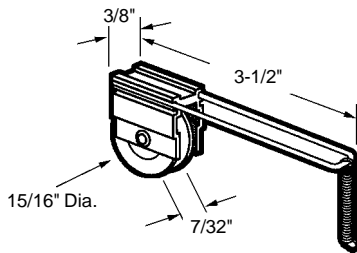

**Sliding Screen Door Roller**

Part Number  
**3-223**  
 Housing: Metal  
 Wheel: Nylon Wheel  
 Unit: Each          Bulk: 10 Pcs.  
 Used By: Several Manufacturers

•Centre Groove

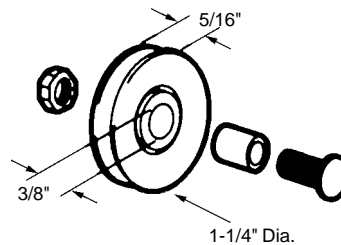

**Sliding Screen Door Roller**

Part Number  
**3-218**  
 Wheel: Nylon Wheel  
 Unit: Each          Bulk: 10 Pcs.  
 Used By: Several Manufacturers

•Centre Groove

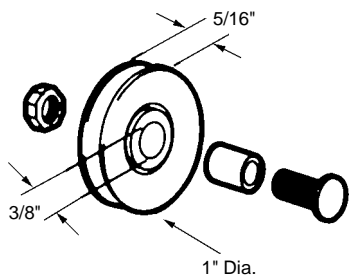

**Sliding Screen Door Roller**

Part Number  
**3-220**  
 Wheel: Nylon Wheel  
 Unit: Each          Bulk: 10 Pcs.  
 Used By: Several Manufacturers

•Off-Set Groove

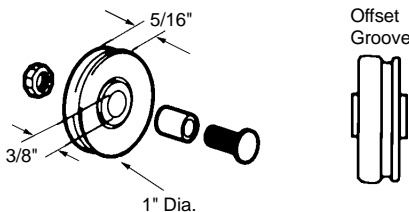

**Sliding Screen Door Roller**

Part Number  
**3-231**  
 Wheel: Nylon Wheel  
 Unit: Each          Bulk: 20 Pcs.  
 Used By: Several Manufacturers

•Wide Groove Wheel  
 •5/16" Overall Thickness

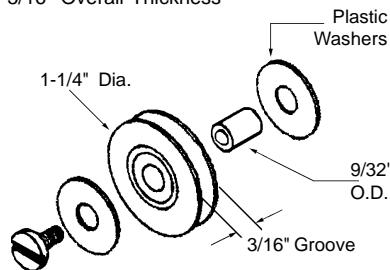

**Sliding Screen Door Roller**

Part Number  
**3-292**  
 Wheel: Plastic  
 Unit: Each          Bulk: 10 Pcs.  
 Used By: Several Manufacturers

•Narrow Groove  
 •5/16" Overall Thickness

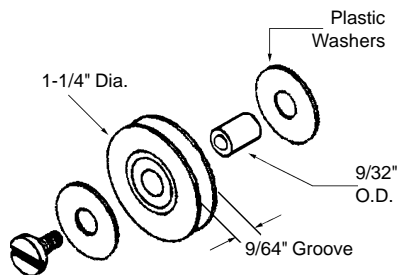

**Sliding Screen Door Roller**

Part Number  
**3-293**  
 Wheel: Plastic  
 Unit: Each          Bulk: 10 Pcs.  
 Used By: Several Manufacturers

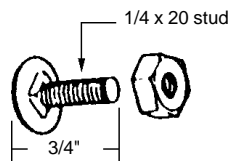

**Sliding Screen Wheel Stud**

Part Number  
**3-227**  
 Unit: Each          Bulk: 10 Pcs.  
 Used By: Several Manufacturers

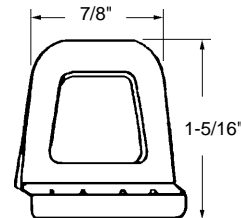

**Window Screen Pull**

Part Number  
**3-1400**  
 Material: Polypropylene  
 Colour: Black  
 Unit: Each          Bulk: 100 Pcs.  
 Used By: Several Manufacturers





# SCREEN CLOTH, LINEALS & HARDWARE

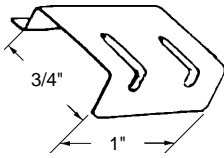

## Window Screen Pull

Part Number  
**3-1422**  
 Material: Aluminum  
 Finish: Mill  
 Unit: Each      Bulk: 100 Pcs.  
 Used By: Several Manufacturers

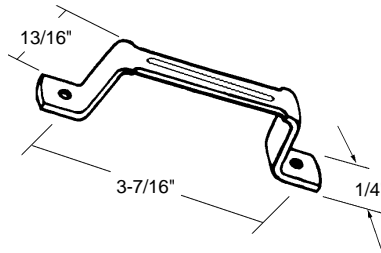

## Window Screen Pull

Part Number  
**3-1438**  
 Material: Aluminum  
 Finish: Mill  
 Unit: Each      Bulk: 50 Pcs.  
 Used By: Several Manufacturers

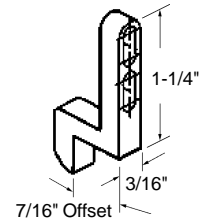

## Sliding Screen Door Strike

Part Number  
**3-267**  
 Material: Plastic  
 Colour: Grey  
 Unit: Each      Bulk: 20 Pcs.  
 Used By: P.H. Tech

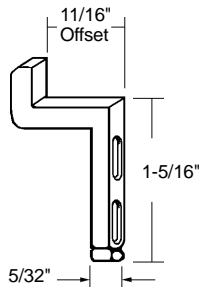

## Sliding Screen Door Strike

Part Number  
**3-259**  
 Material: Die Cast  
 Finish: Mill  
 Unit: Each      Bulk: 20 Pcs.  
 Used By: Several Manufacturers

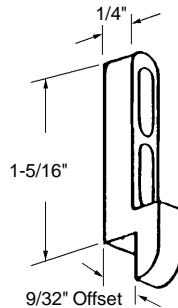

## Sliding Screen Door Strike

Part Number  
**3-258**  
 Material: Die Cast  
 Finish: Mill  
 Unit: Each      Bulk: 10 Pcs.  
 Used By: Several Manufacturers

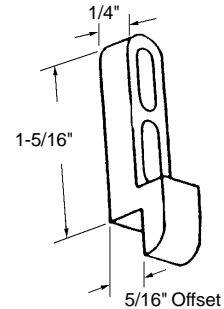

## Sliding Screen Door Strike

Part Number  
**3-261**  
 Material: Die Cast  
 Finish: Mill  
 Unit: Each      Bulk: 10 Pcs.  
 Used By: Several Manufacturers

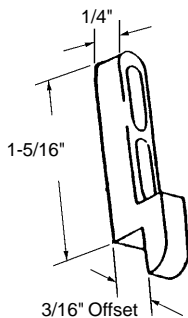

## Sliding Screen Door Strike

Part Number  
**3-262**  
 Material: Die Cast  
 Finish: Mill  
 Unit: Each      Bulk: 10 Pcs.  
 Used By: Several Manufacturers

- Non-handed.
- Mortise installation.

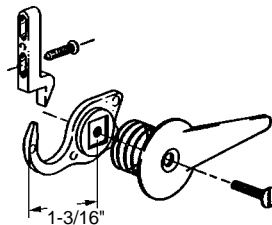

## Sliding Screen Door Latch & Strike

Part Number  
**3-263**  
 Material: Die Cast  
 Colour: Silver  
 Unit: Each      Bulk: 10 Pcs.  
 Used By: Several Manufacturers

- Non-handed.
- Mortise installation.

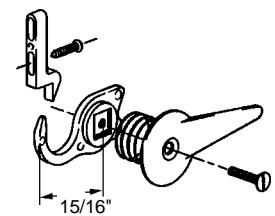

## Sliding Screen Door Latch & Strike

Part Number  
**3-254**  
 Material: Die Cast  
 Colour: Silver  
 Unit: Each      Bulk: 10 Pcs.  
 Used By: Several Manufacturers

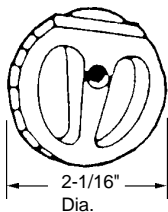

**Sliding Screen Door Latch**

Part Number  
**3-282**  
 Material: Plastic  
 Colour: Stone  
 Unit: Each      Bulk: 10 Pcs.  
 Used By: Andersen

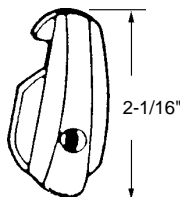

**Sliding Screen Door Latch**

Part Number  
**3-283**  
 Material: Plastic  
 Colour: Stone  
 Unit: Each      Bulk: 10 Pcs.  
 Used By: Andersen

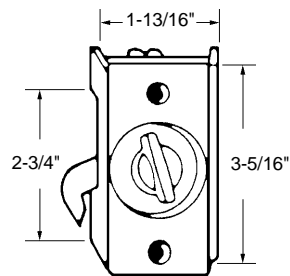

**Sliding Screen Door Latch**

Part Number  
**3-281**  
 Material: Metal  
 Colour: Stone  
 Unit: Each      Bulk: 3 Pcs.  
 Used By: Andersen

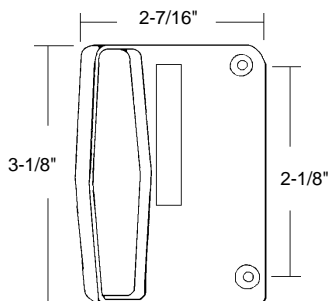

**Sliding Screen Door Inside Pull**

Part Number  
**3-284**  
 Material: Plastic  
 Colour: Stone  
 Unit: Each      Bulk: 5 Pcs.  
 Used By: Andersen

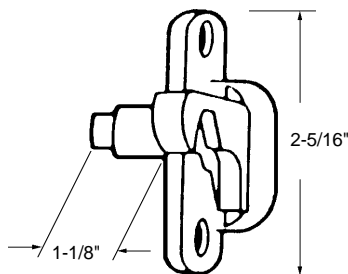

**Sliding Screen Door Latch**

Part Number  
**3-289**  
 Material: Die Cast  
 Colour: Stone  
 Unit: Each      Bulk: 5 Pcs.  
 Used By: Andersen

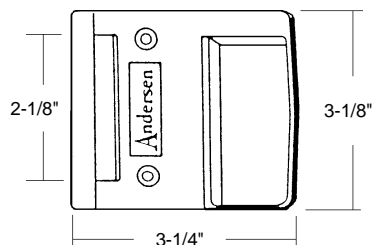

**Sliding Screen Door Pull**

Part Number  
**3-290**  
 Material: Plastic  
 Colour: Stone  
 Unit: Each      Bulk: 10 Pcs.  
 Used By: Andersen

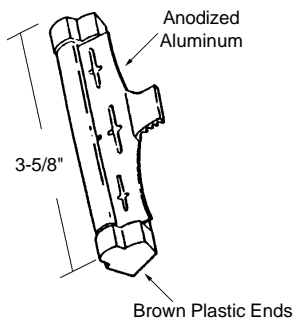

**Sliding Screen Door Handle**

Part Number  
**3-260**  
 Material: Anodized Aluminum/Plastic  
 Colour: Silver/Brown  
 Unit: Each      Bulk: 10 Pcs.  
 Used By: Ador/HiLite

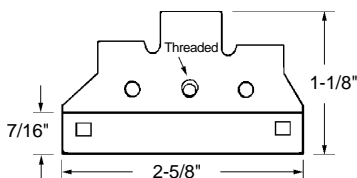

**Sliding Screen Door Lock Bracket**

Part Number  
**3-245**  
 Material: Steel  
 Finish: Mill  
 Unit: Each      Bulk: 20 Pcs.  
 Used By: Indal

•Uses keeper 3-267 (page 3-16).

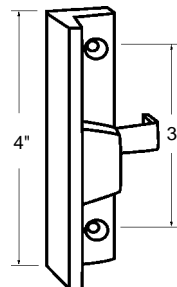

**Sliding Screen Door Handle**

Part Number  
**3-300**  
 Material: Plastic  
 Colour: Black  
 Unit: Each      Bulk: 10 Pcs.  
 Used By: P.H. Tech

# SCREEN CLOTH, LINEALS & HARDWARE

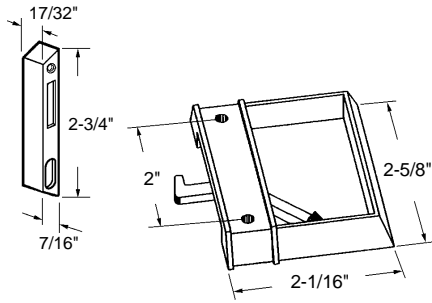

## Sliding Screen Door Handle

Part Number

**3-268**

Material: Metal

Colour: White

Unit: Each Bulk: 5 Pcs.

Used By: Solaris & Others

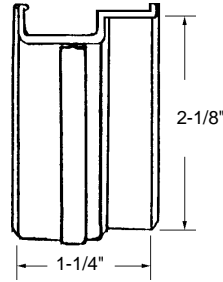

## Sliding Screen Door Lock

Part Number

**3-253**

Material: Plastic

Colour: Black

Unit: Each Bulk: 20 Pcs.

Used By: Supreme

•Heavy Duty

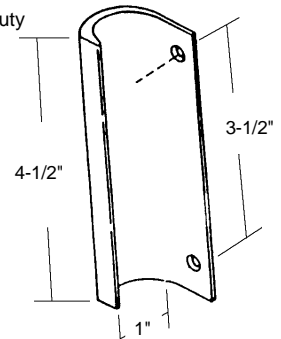

## Sliding Screen Door Pull

Part Number

**3-285**

Material: Anodized Aluminum

Finish: Mill

Unit: Each Bulk: 10 Pcs.

Used By: Trimview

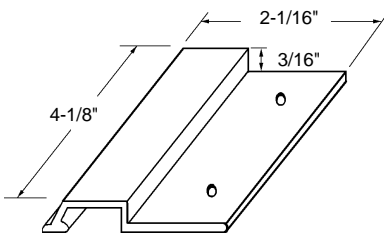

## Sliding Screen Door Handle

Part Number

**3-251**

Material: Plastic

Colour: Black

Unit: Each Bulk: 20 Pcs.

Used By: Several Manufacturers

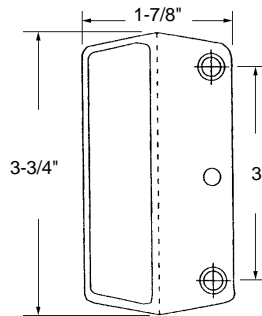

## Sliding Screen Door Handle

Part Number

**3-250**

Material: Plastic

Colour: Black

Unit: Each Bulk: 100 Pcs.

Used By: Several Manufacturers

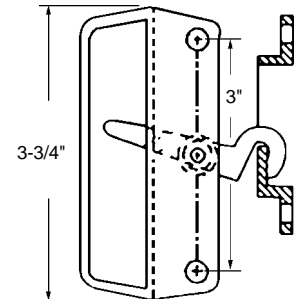

## Sliding Screen Door Lock & Strike

Part Number

**3-301**

Material: Plastic

Colour: Black

Unit: Each Bulk: 10 Pcs.

Used By: Several Manufacturers

•Uses strikes 3-258, 3-259, 3-261 and 3-262 (page 3-16).

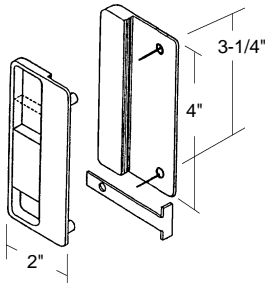

## Sliding Screen Door Latch & Pull

Part Number

**3-270**

Material: Plastic

Colour: Black

Unit: Each Bulk: 10 Pcs.

Used By: Several Manufacturers

•Holes: 3-1/4"  $\phi$  to  $\phi$ .

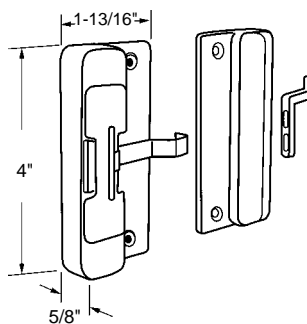

## Sliding Screen Door Handle

Part Number

**3-304**

Material: Plastic

Colour: Black

Unit: Each Bulk: 20 Pcs.

Used By: Several Manufacturers

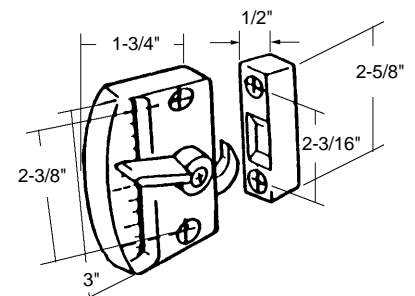

## Sliding Screen Door Handle

Part Number

**3-264**

Material: Die Cast

Finish: Chrome

Unit: Each Bulk: 10 Pcs.

Used By: Several Manufacturers

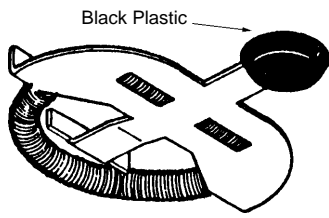

**T-Bird Slide Lock Assembly**

Part Number  
**3-265**  
 Material: Steel  
 Colour: Silver  
 Unit: Each      Bulk: 20 Pcs.  
 Used By: Several Manufacturers

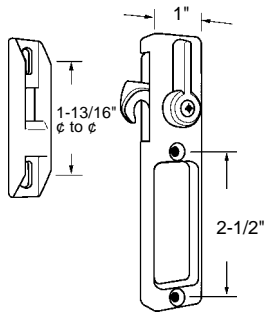

**Sliding Screen Door Handle**

Part Number      Colour  
~~3-266B~~      ~~Brown~~ (Discontinued)  
**3-266W**      **White**  
 Material: Die Cast  
 Unit: Each      Bulk: 10 Pcs.  
 Used By: Several Manufacturers

•Used with screen bar 3-1457 (page 3-4).

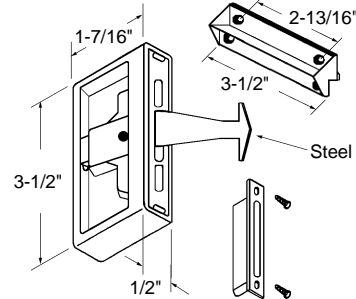

**Sliding Screen Door Locking Handle**

Part Number  
**3-244**  
 Material: Plastic  
 Colour: Black  
 Unit: Each      Bulk: 10 Pcs.  
 Used By: Several Manufacturers

•Used with screen bar 3-1457 (page 3-4).

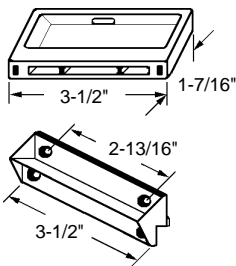

**Sliding Screen Door Pull Handle**

Part Number  
**3-247**  
 Material: Plastic  
 Colour: Black  
 Unit: Each      Bulk: 20 Pcs.  
 Used By: Several Manufacturers

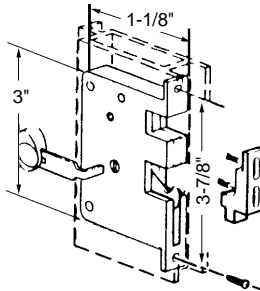

**Sliding Screen Door Lock c/w Strike**

Part Number  
**3-286**  
 Material: Plastic with Steel Strike  
 Colour: Tan  
 Unit: Each      Bulk: 10 Pcs.  
 Used By: Several Manufacturers

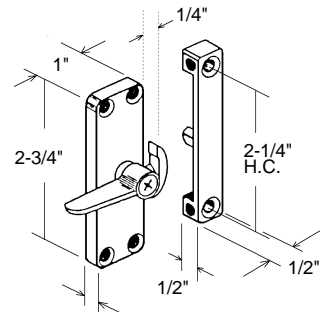

**Sliding Screen Door Latch**

Part Number  
**3-255**  
 Material: Metal  
 Finish: Chrome  
 Unit: Each      Bulk: 10 Pcs.  
 Used By: Several Manufacturers

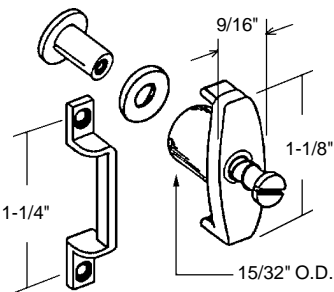

**Sliding Screen Door Latch**

Part Number  
**3-302**  
 Material: Metal  
 Finish: Silver  
 Unit: Each      Bulk: 20 Pcs.  
 Used By: Several Manufacturers

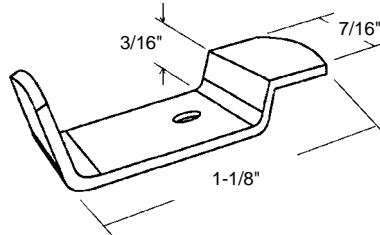

**Screen U-Clip**

Part Number  
**3-1477**  
 Material: Metal  
 Finish: Silver  
 Unit: Each      Bulk: 200 Pcs.  
 Used By: Several Manufacturers

•Press-on assembly.

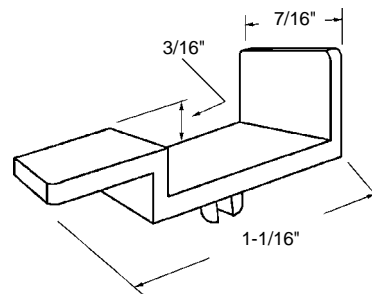

**Screen U-Clip**

Part Number  
**3-1478**  
 Material: Plastic  
 Colour: White  
 Unit: Each      Bulk: 200 Pcs.  
 Used By: Several Manufacturers

# SCREEN CLOTH, LINEALS & HARDWARE

**Discontinued**

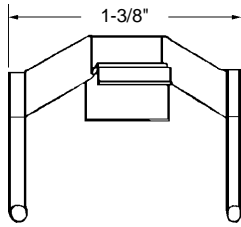

**Screen Clip**

Part Number  
**1418**  
 Material: Plastic  
 Colour: White  
 Unit: N/A  
 Used By: Hialco Series II

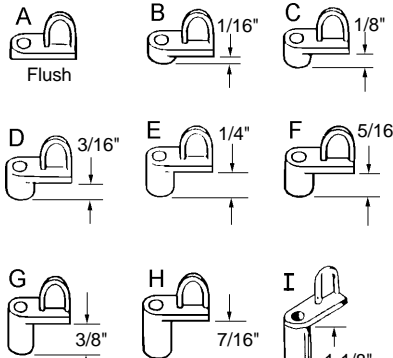

**Screen Clips**

Part Number  
**3-1410A Thru I**  
 Material: Die Cast Zinc (Except 3-1410I)  
 Finish: Mill  
 Unit: Each      Bulk: 100 Pcs.  
 Used By: Several Manufacturers



Polycarbonate

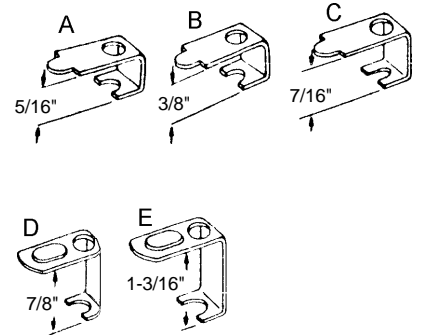

**Screen C-Clips**

Part Number  
**3-1409A Thru E**  
 Material: Aluminum  
 Finish: Mill  
 Unit: Each      Bulk: 100 Pcs.  
 Used By: Several Manufacturers

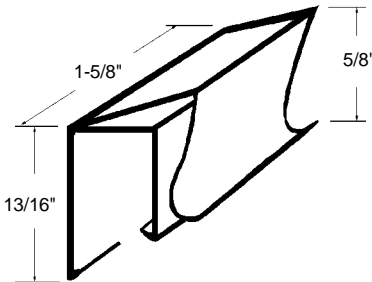

**Screen Clip**

Part Number      Colour  
**3-1480B**      **Brown**  
**3-1480W**      **White**  
 Material: Plastic  
 Unit: Each      Bulk: 100 Pcs.  
 Used By: Several Manufacturers

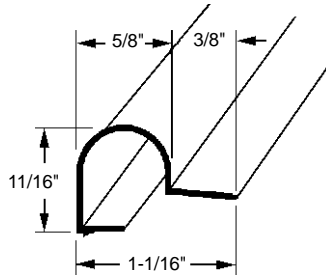

**Screen Retainer Clip**

Part Number  
**3-1440**  
 Material: Plastic  
 Colour: White  
 Length: 3"  
 Unit: Each      Bulk: 25 Pcs.  
 Used By: Indal/C.W.D.

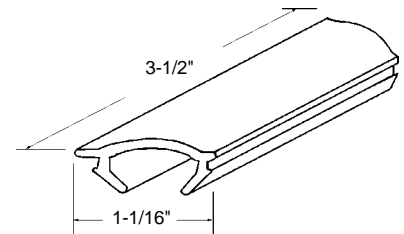

**Screen Retainer Clip**

Part Number  
**3-1465**  
 Material: Plastic  
 Colour: White  
 Unit: Each      Bulk: 100 Pcs.  
 Used By: Willmar

•Top and bottom clips differ slightly.

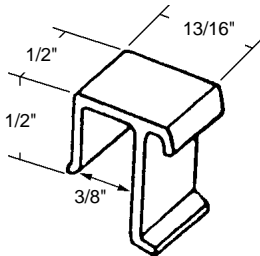

**Screen Retainer Clip**

Part Number  
**3-1425**  
 Material: Plastic  
 Colour: Black  
 Unit: Pair      Bulk: 20 Pair  
 Used By: Several Manufacturers

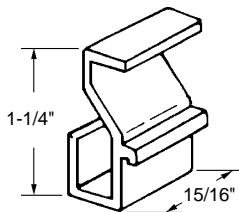

**Screen Retainer Clip**

Part Number  
**3-1426**  
 Material: Plastic  
 Colour: Black  
 Unit: Each      Bulk: 20 Pcs.  
 Used By: Several Manufacturers

Looking for a part,  
 but don't know where  
 to start?  
 The best place to  
 start is our  
 alphabetical index at  
 the front of the  
 catalogue.

**BUTTERFLY STYLE WINDOW SCREEN CLIPS**

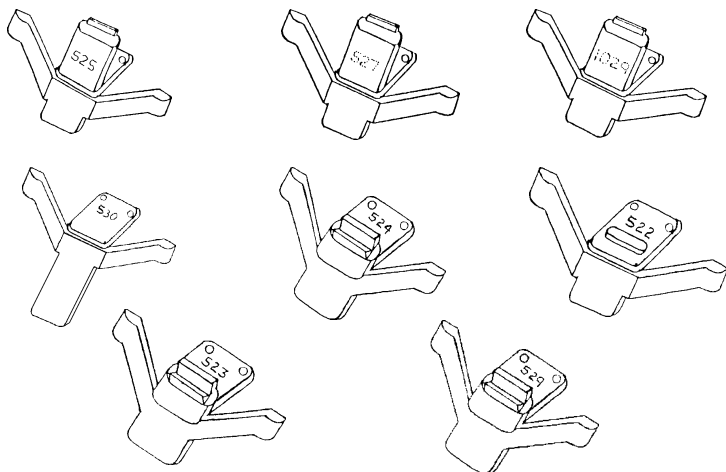

**Screen Clips — Long Style**

Part Number	I.D. Number	A	B	C	D
3-1413	525	.670"	1.230"	.190"	N/A
3-1414	527	.460"	1.050"	.190"	N/A
3-1415	1029	.760"	1.350"	.300"	.280"
3-1429	530	.910"	1.500"	.100"	N/A

**Screen Clips — Short Style**

Part Number	I.D. Number	A	B	C
3-1404	524	.150"	.750"	.050"
3-1411	522	.070"	.650"	.390"
3-1412	523	.150"	.750"	.050"
3-1418	529	.150"	.750"	.290"



Material: Polycarbonate

Colour: Clear

Unit: Each

Bulk: 100 Pcs.

Used By: Several Manufacturers

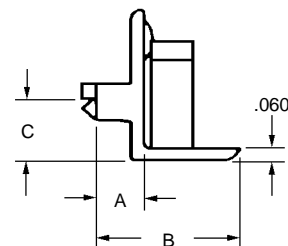
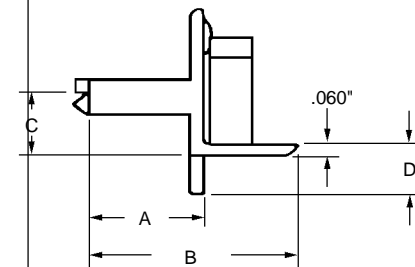
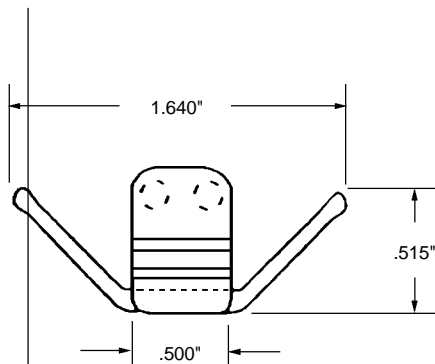

- Step drill, 1-1406-B (page 1-19).
- Spring bolt assembly with metal head and metal shaft.

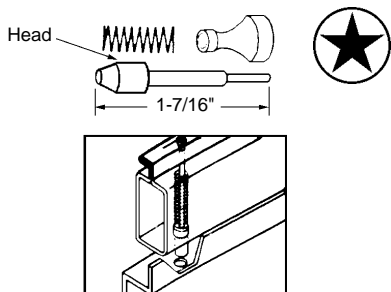

**Screen Plunger Latch**

Part Number	Head Dia.	Bar Size
3-1407	7/32"	3/4"

Material.: Aluminum  
Unit: Each      Bulk: 100  
Used By: Several Manufacturers

- Step drill, 1-1406-B (page 1-19).

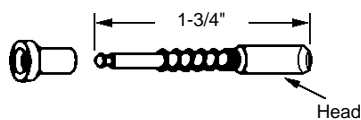

**Screen Plunger Latch**

Part Number	Head Dia.	Bar Size
3-1427	7/32"	1"

Material.: Aluminum Plunger/Plastic Cap  
Unit: Each      Bulk: 100  
Used By: Several Manufacturers

- Step drill, 1-1406-A (page 1-19).

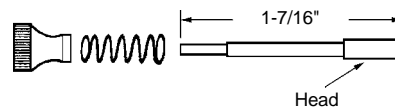

**Screen Plunger Latch**

Part Number	Head Dia.	Bar Size
3-1479	1/8"	3/4"

Material.: Aluminum  
Unit: Each      Bulk: 100  
Used By: Several Manufacturers

# SCREEN CLOTH, LINEALS & HARDWARE

•Step drill, 1-1406 (page 1-19).

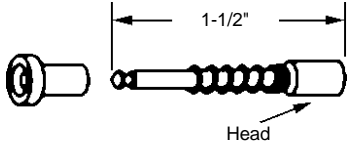

### Screen Plunger Latch

Part Number	Head Dia.	Bar Size
<b>3-1481</b>	<b>5/32"</b>	<b>3/4"</b>

Material.: Plastic  
Unit: Each      Bulk: 100  
Used By: Several Manufacturers

•Step drill, 1-1406-B (page 1-19).

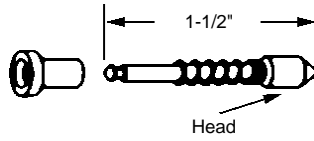

### Screen Plunger Latch

Part Number	Head Dia.	Bar Size
<b>3-1482</b>	<b>7/32"</b>	<b>3/4"</b>

Material.: Plastic  
Unit: Each      Bulk: 100  
Used By: Several Manufacturers

•Step drill, 1-1406-B (page 1-19).

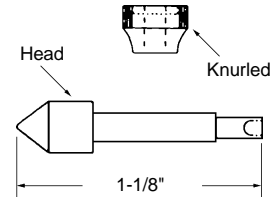

### Screen Plunger Latch

Part Number	Head Dia.	Bar Size
<b>3-1483</b>	<b>7/32"</b>	<b>3/8"</b>

Material.: Aluminum  
Unit: Each      Bulk: 100  
Used By: Several Manufacturers

•Knife latch tool, 1-1400NT (page 1-36).

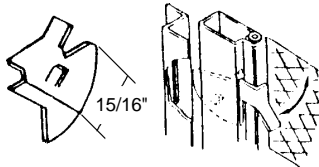

Left Hand Shown

### Screen Knife Latch

Part Number	Hand
<b>3-1405L</b>	<b>Left</b>
<b>3-1405R</b>	<b>Right</b>

Material: Aluminum  
Finish: Mill  
Unit: Each      Bulk: 100 Pcs.  
Used By: Several Manufacturers

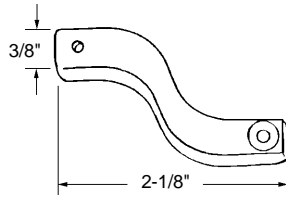
### Tension Spring for Screen or Window

Part Number  
**3-1417**  
Material: Nylon  
Colour: White  
Unit: Each      Bulk: 50 Pcs.  
Used By: Several Manufacturers

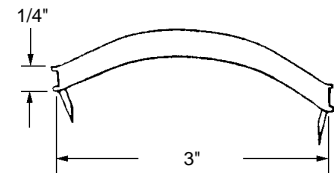

### Screen Tension Spring

Part Number  
**3-1419**  
Material: Steel  
Unit: Each      Bulk: 50 Pcs.  
Used By: Several Manufacturers

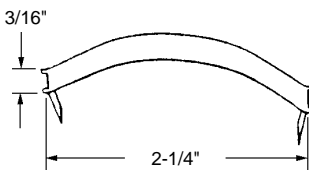
### Screen Tension Spring

Part Number  
**3-1454**  
Material: Steel  
Unit: Each      Bulk: 25 Pcs.  
Used By: Several Manufacturers

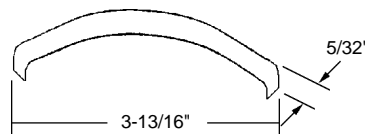

### Screen Tension Spring

Part Number  
**3-1455**  
Material: Steel  
Unit: Each      Bulk: 25 Pcs.  
Used By: Several Manufacturers

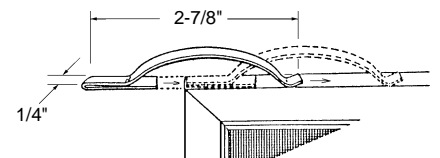

### Slip-In Tension Spring

Part Number  
**3-1428**  
Material: Steel  
Finish: Mill  
Unit: Each      Bulk: 50 Pcs.  
Used By: Several Manufacturers



# SCREEN CLOTH, LINEALS & HARDWARE

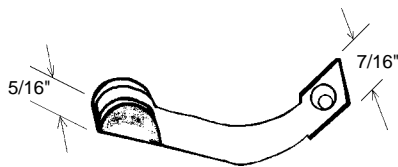

### Top Screen Guide

Part Number

**3-1436**

Material: Nylon

Colour: White

Unit: Each

Bulk: 50 Pcs.

Used By: Several Manufacturers

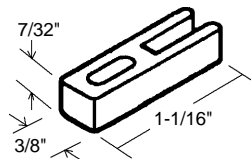

### Sliding Screen Door Guide

Part Number

**3-299**

Material: Plastic

Colour: Beige

Unit: Each

Bulk: 20 Pcs.

Used By: Several Manufacturers

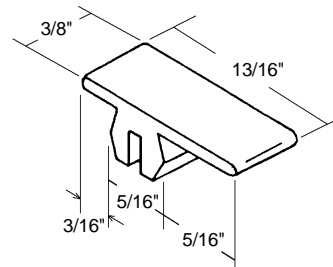

### Sliding Screen Door Top Guide

Part Number

**3-256**

Material: Plastic

Colour: Black

Unit: Each

Bulk: 20 Pcs.

Used By: Several Manufacturers

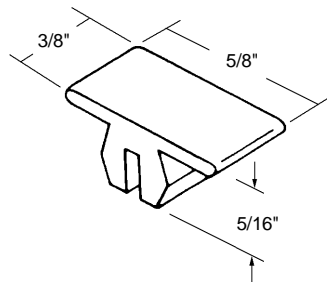

### Sliding Screen Door Top Guide

Part Number

**3-257**

Material: Plastic

Colour: White

Unit: Each

Bulk: 20 Pcs.

Used By: Several Manufacturers

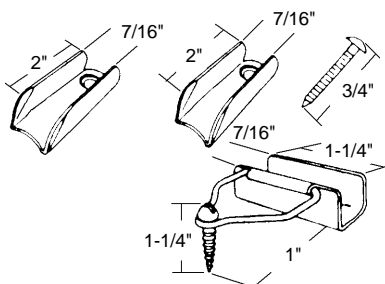

### Jiffy Screen Hanger

Part Number

**3-1424**

Material: Aluminum

Finish: Mill

Unit: Set

Bulk: 20 Sets

Used By: Several Manufacturers

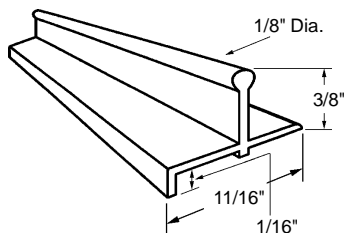
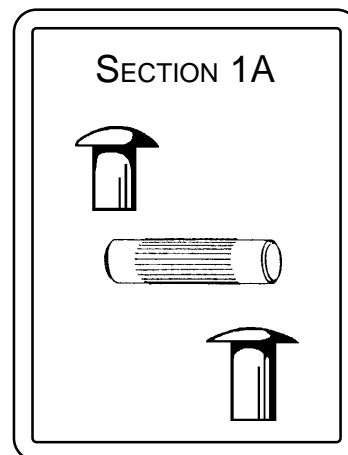

### Sliding Screen & Glass Door Track

Part Number

Length

**4-193-6**

**6 Ft.**

**4-193-12**

**12 Ft.**

Material: Extruded Aluminum

Finish: Mill

Unit: S/L

Bulk: 10 S/L

Used By: Several Manufacturers

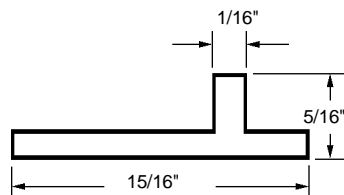

### Sliding Screen & Glass Door Track

Part Number

Length

**4-195-6**

**6 Ft.**

**4-195-8**

**8 Ft.**

Material: Aluminum

Finish: Clear Anodized

Unit: S/L

Bulk: 10 S/L

Used By: Several Manufacturers

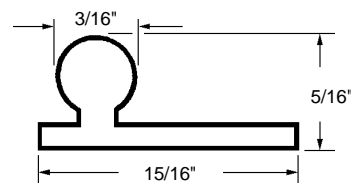

### Sliding Screen & Glass Door Track

Part Number

Length

**4-196-6**

**6 Ft.**

**4-196-8**

**8 Ft.**

Material: Aluminum

Finish: Clear Anodized

Unit: S/L

Bulk: 10 S/L

Used By: Several Manufacturers



# SCREEN CLOTH, LINEALS & HARDWARE

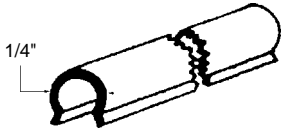

### Bulb Sill Track Cover

Part Number	Length
4-197-6	6 Ft.
4-197-8	8 Ft.

Material: Stainless Steel  
Finish: Mill  
Unit: S/L      Bulk: 10 S/L  
Used By: Several Manufacturers

- Replaces damaged or worn track on glass or screen doors.
- Pop rivet or screw into place.
- Worn rollers should be replaced with track.

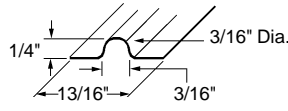

### Sliding Screen & Glass Door Replacement Track

Part Number	Length
4-199-6	6 Ft.
4-199-10	10 Ft.

Material: 24 Gauge Stainless Steel  
Finish: Mill  
Unit: S/L      Bulk: 10 S/L  
Used By: Several Manufacturers

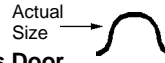

- Replaces damaged or worn track on glass or screen doors.
- Pop rivet or screw into place.
- Worn rollers should be replaced with track.

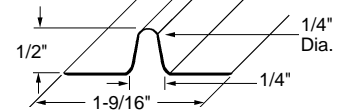

### Sliding Screen & Glass Door Replacement Track

Part Number	Length
4-198-6	6 Ft.
4-198-10	10 Ft.

Material: 24 Gauge Stainless Steel  
Finish: Mill  
Unit: S/L      Bulk: 10 S/L  
Used By: Several Manufacturers

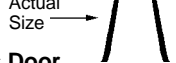

## Custom Heavy Duty Screen Doors

- Solid extruded frame sections.
- Bottom and top have fully adjustable steel ball bearing rollers.
- Available in Brown, Mill (Natural Aluminum) or White.
- Available Fabricated with Metal Screen, K.D. with Metal Screen and K.D. without Metal Screen.
- Recommended replacement track, 4-195-6 (10).

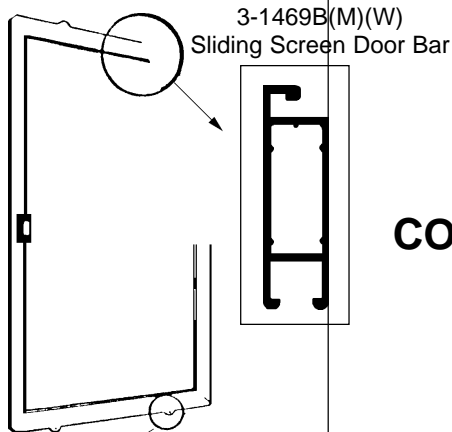

### COMPONENTS

3-242 Steel Ball Bearing Wheel

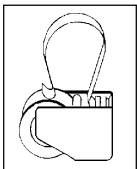

3-287 Screen Door Corner

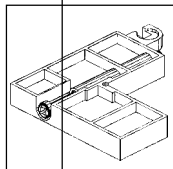

3-250 Screen Door Handle

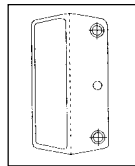

3-SS-200 Screen Spline

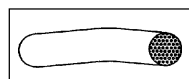

3-1459 Bug Bar

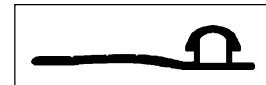

3-254 Locking Handle (Optional)

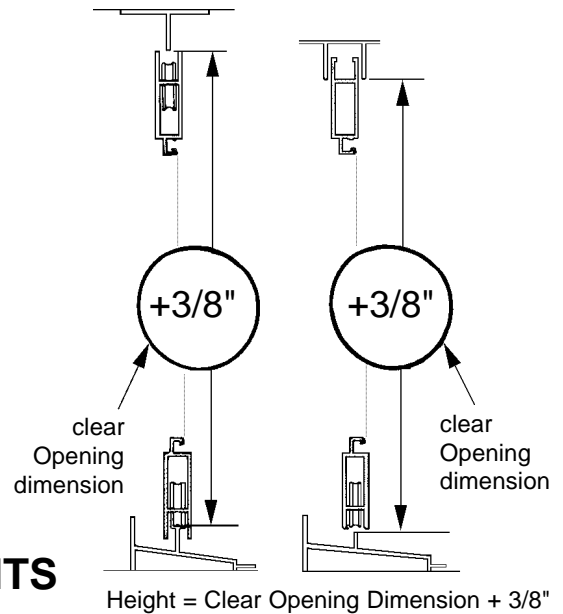
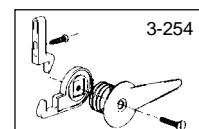

## Custom Size Sliding Screen Door Fabricated with Metal Screen

Part Number	Size Up To	Colour
3-1449B	36" x 84"	Brown
3-1449M	36" x 84"	Mill
3-1449W	36" x 84"	White
3-1450B	48" x 84"	Brown
3-1450M	48" x 84"	Mill
3-1450W	48" x 84"	White
3-1451B	60" x 84"	Brown
3-1451M	60" x 84"	Mill
3-1451W	60" x 84"	White

## K.D. with Metal Screen

3-1446B	36" x 84"	Brown
3-1446M	36" x 84"	Mill
3-1446W	36" x 84"	White
3-1447B	48" x 84"	Brown
3-1447M	48" x 84"	Mill
3-1447W	48" x 84"	White

3-1448B	60" x 84"	Brown
3-1448M	60" x 84"	Mill
3-1448W	60" x 84"	White

## K.D. without Screen

3-1441B	36" x 84"	Brown
3-1441M	36" x 84"	Mill
3-1441W	36" x 84"	White
3-1442B	48" x 84"	Brown
3-1442M	48" x 84"	Mill
3-1442W	48" x 84"	White
3-1443B	60" x 84"	Brown
3-1443M	60" x 84"	Mill
3-1443W	60" x 84"	White

Material: Extruded Aluminum

Unit: Each Bulk: 10 Doors

Manufactured By: All Glass Parts Inc.

- Locking 8" x 10" swinging door.
- Quick and easy installation.
- Mounts directly into the screening of a door or window screen.
- Magnetic closure.

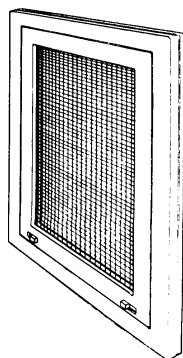

## Heavy Duty Extruded Sliding Screen Door

- Refer to appropriate part in price pages for pricing.
- Provide size you require, in writing, to order desk.
- Custom sizes are manufactured to  $\pm 1/16"$ .

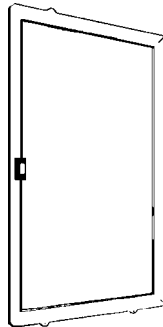

Installation of locking handle is extra.

For jumbo sizes please call our order desk for quotation.

Screen doors can be manufactured with different bar (page 3-4) – phone our order desk for quotation.

## How to Install Your Pet Screen Door

**1** Please read all instructions carefully before you begin installation.

**2** Decide which screen door or window you'd like your pet to use for entry/exit. Remove it, and place it on a hard, flat surface, with the outside of the screen facing up.

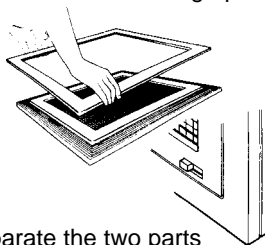

**3** Now separate the two parts of your All Glass Pet Screen Door, making sure that the locks on the frame are in the unlocked position.

**4** Place the frame (with grooves up) under your door or window screen in the location most convenient for your pet. Centre of pet screen door should be at pet's shoulder height.

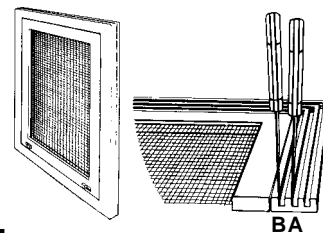
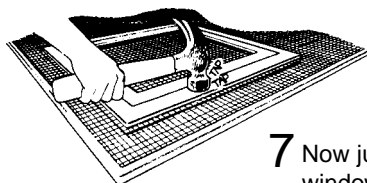

**5** Now determine if your screen door or window is metal or fiber. If it is metal, cut around the entire edge of "A" with a small, sharp knife, using the grooves as a guide. If your screen is fiber, cut around the entire edge of "B", using the grooves as a guide. Be sure to hold the pet screen door frame solidly in place with one hand so it doesn't move during cutting. Remove the cut-out portion of the screen.

**6** Place the front section of the outer frame into position on the back section, *trapping* the cut edge of the screen. Using a hammer, tap the two frame sections together until they are firmly joined all around.

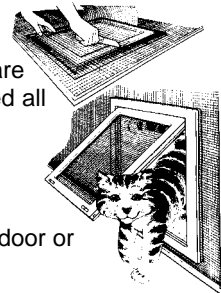

**7** Now just replace your screen door or window, and relax.



**THE LARGEST VARIETY,  
FINEST QUALITY AND BEST SELLING  
ENERGY CONSERVING PET DOORS.**

**5 REASONS WHY PET DOOR CUSTOMERS PREFER  
THE PET-EZE DELUXE SERIES  
(and why you will sell more pet doors)**

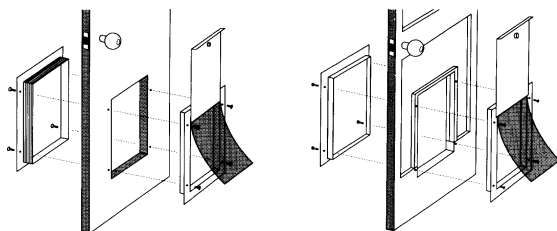

1. All weather self-sealing flap that is clear, soft, safe and quiet, with new energy saving design.
2. Solid construction with heavy duty anodized aluminum frame.
3. Four permanent magnets for positive seal every time.
4. Adjustable frame fits any thickness door from 1/4" to 2" thick. Conceals and protects exposed core and creates its own frame for hollow core doors.
5. Heavy gauge steel locking security cover.



**Deluxe Series Pet Door**

Part Number	Flap Opening	Pet Size
3-1460	5 x 7	For cats up to 15 lbs. and small dogs up to 7 lbs.
3-1461	8 x 11	For dogs up to 60 lbs.
3-1462	10 x 15	For dogs up to 100 lbs.
3-1463	13-3/4" x 23"	For dogs up to 200 lbs.

Material: Aluminum/Steel  
 Finish: Clear Anodized  
 Unit: Each                      Bulk: 3 Pcs.  
 Manufactured By: Pet-eze

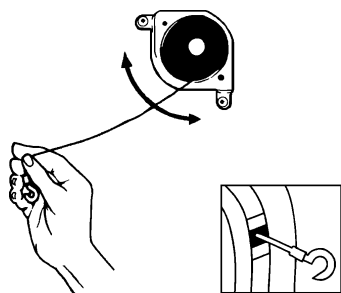

**Automatic Sliding Screen  
Door Closer**

Part Number  
**3-276**  
 Material: Plastic  
 Colour: White  
 Unit: Each                      Bulk: 5 Pcs.  
 Used By: Several Manufacturers

- One piece construction.
- Hinges and locking catch are built in.
- Simple installation, just two pop rivets or use two No. 6 sheetmetal screws, and you are ready for screening.
- An added convenience, the hinged portion of the screen can be detached for separate flat screening.

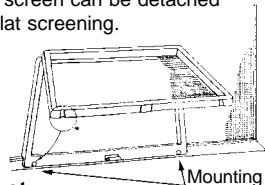

**Screen Wicket**

Part Number                      Colour  
**3-1416B**                      Rideau Brown  
**3-1416W**                      White  
 Material: Durable A.B.S.  
 Approximate size: 10" wide x 6" high  
 Unit: Each                      Bulk: 10 Pcs.  
 Used By: Several Manufacturers